

SB 202

Mix Design Specialist

CERTIFICATION MANUAL



**Partners
in Quality**





The Hot Mix Asphalt Center exists to certify, train, and equip specialists with the knowledge and skills needed to inspect, test, and design construction materials. Through education and support that continue beyond certification, the HMACE seeks to help people realize their potential to contribute to the future of Texas' infrastructure.

To execute our mission, we constantly aim to:

EDUCATE

Through hands-on learning, training, and testing, our instructors ensure specialists not only have a thorough understanding of the subject, but will be able to apply what they've learned in a real-world setting. We believe our role as an educational resource doesn't stop at the door – it continues throughout a specialist's career.

INNOVATE

From installing the latest, cutting-edge equipment in our labs to streamlining processes and developing new educational tools, we strive to continuously set a higher bar for ourselves and those around us.

EMPOWER

We believe in the potential of every specialist who comes through the center and do all we can to help them be successful before, during, and after certification. Our mantra is that what you do matters. If you put in the work to be the best you can be, we'll be here to cheer you on and support you along the way.

SERVE

Service is at the core of everything we do. Whether it be for individuals, companies, TxDOT, or the traveling public, the goal is for every certification to result in improved quality of asphalt pavements across the state of Texas.



SB202 Mix Design Specialist

TABLE OF CONTENTS

Rights and Responsibilities

Website

Tex-113-E Moisture-Density Curve for Base, Coarse, and Treated Materials

Tex-117-E Triaxial Compression for Disturbed Soil and Base Materials (Part 2)

Tex-120-E Cement Treated Materials (Part 2)

Tex-121-E Lime Treated Materials (Parts 2 & 3)

Tex-128-E pH Testing of Soils and Retaining Wall Backfill

Item 247 Flexible Base

Item 260 Lime Treatment (Road Mix)

Item 276 Cement Treatment (Plant Mix)

©2023 HMAC - All Rights Reserved

No part of this publication may be reproduced, stored in a retrieval system or transmitted in any form or by any means, mechanical, electronic, photocopying, recording or otherwise without the prior written permission of the Texas Asphalt Pavement Association.



HMAC CERTIFIED SPECIALIST & APPLICANTS FOR CERTIFICATION: RIGHTS AND RESPONSIBILITIES

This agreement (the "Agreement") affirms that, _____, the below Applicant for Certification or the current Certified Specialist (collectively, the "Specialist") seeks to meet or has successfully met the requirements for certification by the Texas Asphalt Pavement Association ("TXAPA"), a/k/a the Hot Mix Asphalt Center (HMAC) as a certified technician. In that connection, the Specialist agrees as follows:

RIGHTS AND RESPONSIBILITIES - HMAC certification includes the exclusive right to perform certified sampling, testing and reporting on Texas Department of Transportation (TxDOT) projects involving Hot Mix Asphalt (HMA) and Soils & Base (SB) in accordance with TxDOT specifications and test procedures (as may be amended by TxDOT from time to time) for the level of certification issued. Specialists are required to perform and report test results with the accuracy and precision required of a certificated HMA or SB Specialist. It is important that the Specialist fully understands the significance of performing these duties in accordance with the certification level received by the Specialist.

Each Specialist is responsible for performing their own independent sampling, testing and reporting in accordance with TxDOT specifications, test procedures and standard operating procedures. These duties must be performed in a diligent and professional manner to produce TxDOT projects of the highest possible quality.

CONTACT INFORMATION - It is the Specialist's responsibility to provide the HMAC with current contact information by logging into www.txhmac.org. Communications from the HMAC will primarily be sent electronically to the most recent contact information provided by the Specialist.

ANNUAL PROFICIENCY - Once certified, Specialists are required to complete annual proficiency testing and the reporting of results to the HMAC. The testing and reporting must be timely and independently performed by the Specialist and, where applicable, in conformance with the requirements of the Specialist's certifications. TxDOT will ship the annual proficiency samples to the Specialist's address of record. (If this address is not current, the Specialist may not timely receive a proficiency sample and his/her certification may be danger of lapsing.)

Failure to submit proficiency test results or to respond to low rating(s) by the appointed deadlines may result in a change of certification status from active to inactive. Specialists whose certifications are inactivated because their annual proficiency testing/reporting is not current or whose certifications have been revoked or inactivated are prohibited from performing the duties associated with all certifications held by that Specialist.

RECERTIFICATION - Certification(s) are valid for three (3) years from the date originally issued, after which the Specialist must be recertified by again passing the requirements for certification. Specialists may seek recertification up to one year prior to the expiration of their certificate(s).

Failure to timely obtain recertification will cause all dependent certifications held by a Specialist to be inactivated. It is the Specialist's responsibility to maintain an active certification(s). (The HMAC will not provide reminders of pending expiration dates.)

ALLEGATIONS OF MISCONDUCT - Allegations of misconduct should be submitted to the HMAC, P.O. Box 1468, Buda, TX 78610 and must include the name, address and signature of the individual asserting the allegations as well as a brief description of the allegations.

If the allegations are properly submitted and appear to have merit, the HMAC Steering Committee (the "Committee") the individual asserting misfeasance and the person so accused will be asked to meet in person (but at separate dates/times) with members of the Committee. At the conclusion of the meeting(s), the Committee will issue its determination.

Misconduct generally consists of (i) neglect, (ii) abuse and/or (iii) breach of trust which are generally defined as:

1. Neglect: unintentional deviation(s) from specifications or testing procedures;
2. Abuse: careless or deliberate deviation from specifications or testing procedures; and
3. Breach of Trust: violation of the trust placed in Certified Specialists including, but not limited to, acts such as:
 - a. Falsification of or deliberate omission from material records or information; or
 - b. Awareness of improprieties in sampling, testing and/or production by others and the failure to timely report those improprieties to the appropriate project supervision.

The Committee may issue written reprimands (private or public) and/or revoke or inactivate a certification (if the Specialist has made a false representation or misstatement to the Committee or to the public or has engaged in misconduct) or take such other actions as the Committee, in its sole discretion, determines to be appropriate with respect to the Specialist's certification(s).

Specialists who do not achieve recertification or whose certification is revoked or inactivated by the Committee may appeal to a separate appeals committee comprised of industry members (the "Appeal Committee"). The exhaustion of this right of appeal to the Appeal Committee is a prerequisite to the exclusive remedy of administrative review by final and binding arbitration in Hays County, Texas, as administered by the American Arbitration Association by a single-member panel. Any and all other claims related in any way to this Agreement are exclusively subject to final and binding arbitration in Hays County, Texas as administered by the American Arbitration Association by a single-member panel.

In consideration for the HMAC certification/recertification process, Specialist hereby waives any and all claims of whatsoever kind or character related, directly or indirectly, to this Agreement, against the TXAPA, HMAC (including, but not limited to, the Committee and the Appeal Committee and their members), that s/he may have (including claims for attorney's fees) and further agrees to save, indemnify and hold TXAPA, the HMAC (including, but not limited to, the Committee and the Appeal Committee and their members) harmless from any claim, action or cause of action arising as a result of, or relating to this Agreement including, but not limited to, Specialist's certification, or any refusal, reprimand, revocation and/or suspension of certification or recertification of Specialist.

ACKNOWLEDGED & AGREED:

SPECIALIST:

SIGNATURE

DATE

PRINTED NAME



WEBSITE

It is your responsibility to keep your information up-to-date.

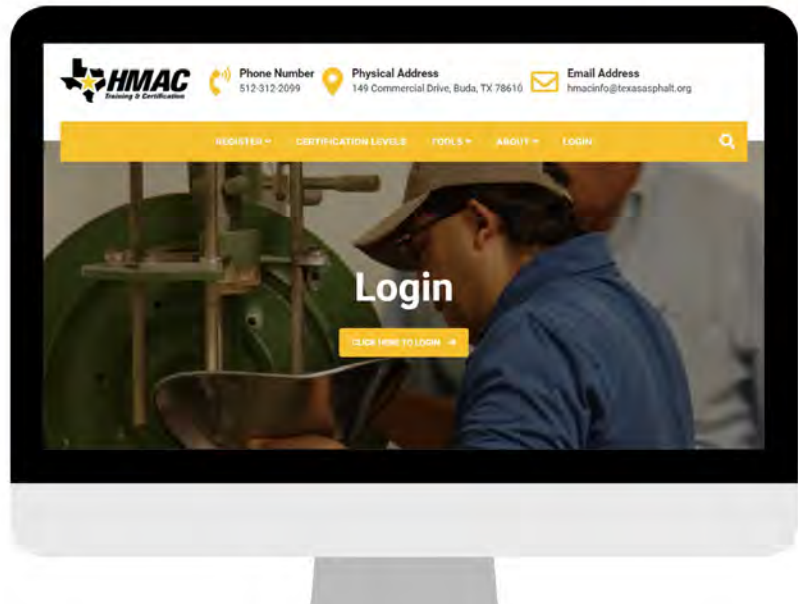

FIRST TIME LOGIN

Username

Capitalize the first letter of your first and last name then spell out the rest of your last name in lower case, followed by the last 4 digits of your SSN.

Password

Same as your username, but add a "+" at the end.

Example

If your name is John Doe and your SSN ends in 1234:

Username: JDoe1234

Password: JDoe1234+





UPDATE INFORMATION

Contact Info

Username * (004) 1234

E-mail * 004@hmac.com

Work Email * 004@hmac.com

First Name * John

Last Name * Doe

Company * HM&C

Company Type * I&C (I/Her)

Last 4 digits of SSN * 1234

Cell Phone * (512) 312-2299

Password

Change Password * To change password, enter new password here.
(Leave it blank if not changing.)

Repeat Password * Type your new password again

Verify that all information is correct.



UPDATE INFORMATION

**VIEW/PRINT
CERTIFICATIONS
PROFICIENCY**

Certification

Cert Name	Cert Date	Cert Num	Expiration Date	Status	
1A	07/27/2018	9982	07/27/2021	Active	View Certificate
1B	04/27/2018	2723	04/27/2021	Active	View Certificate
2	02/06/2015	647	02/06/2018	Active	View Certificate
A00101	08/08/2018	9085	08/08/2021	Active	View Certificate

[Proficiency Instructions](#) [Annual Proficiency Required](#)

Self Class

Cert Name	Cert Date	Cert Num	Expiration Date	Status
SB101	02/23/2008	002	02/23/2009	Inactive
SB102	02/23/2008	41	02/22/2009	Inactive
SB201				
SB202				

Prerequisite: SB201 is required

Test Procedure for**MOISTURE-DENSITY CURVE FOR BASE, COARSE, AND TREATED MATERIALS**

TxDOT Designation: Tex-113-E

Effective Date: January 2025

1 SCOPE

- 1.1 This procedure produces a moisture-density curve for flexible base, coarse-grained materials containing particles larger than 7/8 in., and treated embankment (soils) and base materials that are plant or road-mixed. Coarse-grained materials may include embankment (soil) and retaining wall backfill. Treated materials includes any material that is plant or road-mixed with an approved additive such as cement, emulsion, foamed asphalt, or lime. This procedure also applies to materials mixed with non-approved additives.
- 1.2 Sampled material is compacted using an automatic tamper (compaction) device into a mold to produce a molded specimen with a diameter of 6 in. and a height of 8 in. It compacts material in 4 lifts with a 10 lb. hammer and 18 in. drop height. A slide finishing hammer is used to ensure the top surface of the mold is level.
- 1.3 The compaction device is equipped with a Soil Compactor Analyzer (SCA). The SCA monitors and records the compacted effort of the molded specimen to ensure the required total energy of 750 ± 15 ft.-lb. is achieved within 50 – 60 blows for each lift.
- 1.4 The density and moisture content of compacted molds are used to produce a moisture-density curve. This will provide a maximum dry density and an optimum moisture content. The maximum dry density is the peak of this curve. The optimum moisture-content is the moisture content at the maximum dry density. This is the water content at which material can be compacted to achieve the maximum dry density.
- 1.5 *This test procedure does not claim to address the safety concerns associated with its use. It is the responsibility of the user of this test procedure to establish the appropriate safety, health, and environmental practices and determine the applicability of regulatory limitations before use.*
-

2 APPARATUS

- 2.1 *Automatic tamper (compaction) device*, with base plate to hold 6-in. inside diameter mold, equipped with a 10 ± 0.02 lb. rammer, and an adjustable height of fall. Includes the following.
- 2.1.1 *Rammer*, with a striking face that conforms to a $43 \pm 2^\circ$ segment of a 2.9 ± 0.1 in. radius circle.
- 2.1.2 *Rigid foundation*, to bolt the base plate of the compaction device to, such as a concrete block or rigid stand or table, with a weight greater than 200 lb.
- 2.2 *Balance*, Class G2 in accordance with [Tex-901-K](#), with a minimum capacity of 35 lb. readable to the nearest 0.0002 lb. (0.1g).
-

- 2.3 *Compaction mold kit*, includes a metal mold with a 6 in., +1/16, or -1/64 in. I.D. and 8.5 ± 1/16 in. height, base plate, hold down ring, and a collar.
- 2.4 *Measuring Assembly*, to measure the height of molded specimens. Includes the following.
- 2.4.1 *Gauge blocks*, 1, 4, 6, and 11 in. with a tolerance of ± 0.001 in.
- 2.4.2 *Indicator*, dial or digital micrometer indicator with 2 in. travel.
- 2.4.3 *Rigid stand*, with a solid level base and stable vertical post, capable of holding the dial or digital indicator above molded specimen and able to be adjusted to increase and decrease height.
- 2.5 *Metal pans with lids*, used for mixing and drying of material.
- 2.6 *Miscellaneous tools*, bristle brush, level, plastic mallet, and spatula.
- 2.7 *Mixing tool, scoop, spoon, or trowel*.
- 2.8 *Non-absorptive bowls with lids*, used to hold aggregate retained on the 7/8 in. sieve.
- 2.9 *Porous stones*, circular, with a diameter less than 6 in. and a height of 2 in.
- 2.10 *Paper discs*, non-porous with a diameter of 6 in. to fit inside the compaction mold.
- 2.11 *Oven*, capable of maintaining a temperature of 230 ± 9°F.
- 2.12 *Sample extruder*, hydraulic, automatic or manual to safely extrude a compacted specimen from the mold with no damage.
- 2.13 *Sieves*, circular with square, wire cloth openings meeting the requirements of [Tex-907-K](#).
- 2.14 *Slide hammer finishing tool and pedestal*, hammer is built with a drop weight that moves along a vertical, fixed shaft meeting the dimensions and tolerances shown in Figure 1. The hammer shown in the figure may not be representative of what may be commercially available.
- 2.15 *Soil Compactor Analyzer (SCA)*, includes a sensor rod assembly, data acquisition system, and software that stops compaction when the required energy has been delivered to the compacted lift.
- 2.15.1 SCA reference guide is available online at the following link
<https://www.txdot.gov/business/resources/materials.html>.
- 2.16 *Sprinkling jar*.
- 2.17 *Wash bottle*.

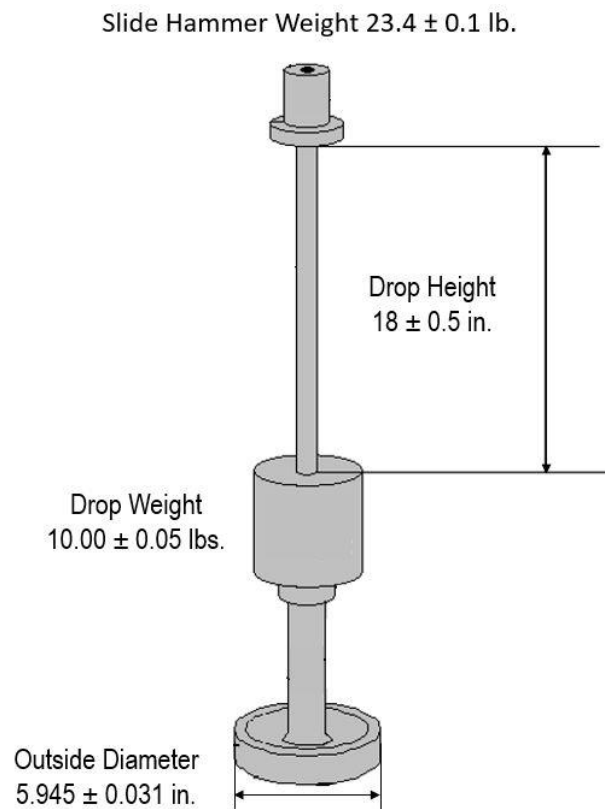

Figure 1
Slide Finishing Hammer

3 MAINTENANCE OF AUTOMATIC TAMPER (COMPACTOR)

- 3.1 Wipe the guide rods and disc with a wet rag after each use.
- 3.2 Wipe the guide rods and disc with alcohol weekly to ensure no oil or residue begins to build up on them.
- 3.3 Lubricate the guide disc before compaction with graphite. The rods will become lubricated by picking up a bit of the graphite from the edge of the disc during compaction.
- 3.4 Check the guide rod brackets weekly. There should be very little to no play between the rods and the brackets. If the play is excessive, **adjust or** replace the brackets.
- 3.5 Inspect the grabber assembly, belts, cables, height adjuster and rod and all other compactor parts for excessive wear. Replace or repair the necessary parts as needed.
- 3.5.1 The grabber assembly should be replaced as a whole because the individual parts of the assembly wear together but not uniformly.

4 SAMPLING

- 4.1 Sample material in accordance with [Tex-100-E](#).

- 4.1.1 Sample coarse-grained materials with particles larger than 7/8 in. such as embankment (soil) or non-select retaining wall backfill in accordance with Section 3 of [Tex-100-E](#).
- 4.1.2 Sample flexible base or select retaining wall backfill from stockpiles in accordance with Section 4 of [Tex-100-E](#).
- 4.1.3 When sampling flexible base to approve a stockpile as required in Item 247, "Flexible Base," prepare the sampled material in accordance with Section 6 of [Tex-100-E](#).
- 4.1.4 Sample from the roadway for reclamation (road-mixed) and treatment in accordance with Section 3 of [Tex-100-E](#).
-

5 PREPARING SAMPLE

- 5.1 Prepare the material after sampling in accordance with [Tex-101-E](#), Part II to determine a bulk gradation.
- 5.2 Estimate the weight of dry material to fill a mold to produce a compacted specimen with a height of 8 ± 0.250 in.
- 5.3 Use the bulk gradation from Section 5.1 and determine the weight of material retained on each sieve. Use the equation from Section 8.1 to calculate the weight of material retained on each sieve. Alternatively, use the equation from Section 8.2 to determine the weight on each sieve cumulatively.
- 5.4 Determine the tare weight of a mixing pan to the nearest 0.001 lbs. This will be used in Section 6.3.
- 5.5 Weigh a trial sample in the mixing pan from Section 5.4 with each size of material to the nearest 0.1 lb. (5 g) to the estimated weight from Section 5.2.
- 5.5.1 Do not use aggregate larger than 1-3/4 in.
- 5.5.2 When material contains aggregate retained on the 1-3/4 in. sieve, replace this amount of aggregate with the same amount of aggregate from passing the 1-3/4 in. and retained on the 1-1/4 in. sieve.
- 5.5.3 Material may be weighed based on the individual or cumulative weights.
- 5.6 Estimate a percent moisture at optimum and calculate the weight of water using equation from Section 8.3 to add based on the mass of the total dry weight.
- 5.6.1 The plastic limit of the material may be used as an estimated moisture content.
- 5.6.2 When electing to not compact a trial sample, weigh a minimum of four samples to produce the moisture-density curve. Estimate a percent moisture at optimum and start the curve at 2% below this estimate. Increase the percent moisture from this percent by 1% for each additional sample.
- 5.6.3 The difference in the moisture contents between the samples to produce the moisture-density curve cannot exceed 1%.
- 5.6.4 Calculate the weight of water at each percent moisture using equation from Section 8.3 to add to each sample based on the mass of the total dry weight.
- 5.6.5 The moisture-density curve must have results from at least two moisture contents below and two greater than the optimum moisture content.

- 5.7 Add the weight of water calculated from Section 5.6 into a tared sprinkling jar.
- 5.8 Add water from the sprinkling jar in increments of approximately 1/3 to the sample in the mixing pan weighed from Section 5.4.
- 5.9 After adding water, mix the sample thoroughly breaking up any lumps of material. Do not excessively mix the material that may break aggregate particles in the sample. Scrape all material off the mixing tool into the pan.
- 5.10 Weigh the wet sample and pan without the lid and record the weight to the nearest 0.001 lb.
- 5.11 Cover the mixture with a non-absorptive lid to prevent moisture evaporation and allow the trial sample to stand for a minimum of 2 hr. before compaction.
- 5.11.1 Only the trial sample may be allowed to stand undisturbed for a minimum of 2 hr. before compaction. The 2-hr. trial sample cannot be used for the moisture-density curve.
- 5.11.2 When the sample will be used to produce the moisture-density curve, it must be allowed to stand undisturbed for 18–24 hr. before compaction.
- 5.12 After the required number of hours from Section 5.11, weigh the sample and pan without the lid to the nearest 0.001 lb. Replace evaporated water to the weight from Section 5.10, and thoroughly mix to ensure even distribution of water throughout the sample. Scrape material off mixing tool and into the pan.
- 5.12.1 Water from the sprinkling jar or wash bottle may be used to rinse the mixing tool into the sample. Do not exceed the weight of the water evaporated.
- 5.13 When the sample will be used to produce the moisture-density curve, allow the sample to stand an additional 1 – 2 hr. before compaction. Do not exceed 2 hr. This is not required for the 2-hr. trial sample from Section 5.11.
- 5.14 Cover and proceed to Section 6 to compact the sample.
- 5.15 The entire sample must be used to compact the molded specimen. Do not discard any amount of material.
-

6 PROCEDURE

- 6.1 Weigh a clean compaction mold and record this weight to the nearest 0.001 lb.
- 6.2 Place one non-porous paper disc in the bottom of the mold.
- 6.3 Determine the weight of material for each lift by subtracting the tare weight of the pan from Section 5.4 from the weight recorded in Section 5.12. Divide this weight by four.
- 6.4 Sieve the sample by hand over a 7/8 in. sieve.
- 6.5 Distribute the material retained on the 7/8 in. sieve equally, based on size, shape, and number of particles, into four separate non-absorptive bowls.
- 6.5.1 Cover each bowl to prevent loss of moisture.
- 6.5.2 Using a bristle brush, brush the material stuck to the 7/8 in. sieve back into the pan containing the material passing the 7/8 in. sieve.

- 6.5.3 Divide the material passing the 7/8 in. sieve into four equal portions.
- 6.6 Weigh one of the portions of material retained on the 7/8 in. sieve with one of the portions of material passing the 7/8 in. sieve, adjusting the amount of material as needed to attain the estimated **calculated** weight for one lift from Section 6.3.
- 6.6.1 The entire sample must be used to compact a mold. Do not discard any amount of material.
- 6.7 Cover the bottom of the mold with approximately 1/4 in. of material passing the 7/8 in. sieve and level with a spatula.
- 6.8 Hand place all of the aggregate particles retained on the 7/8 in. sieve that are contained in one of the non-absorptive containers, minimizing contact with the edges of the mold.
- 6.9 Place aggregates in their most stable position. Aggregates may be placed on top of each other to make them all fit, but they must also fill the entire diameter of the mold.
- 6.10 Use a scoop held slightly above the top of the mold to pour the remaining weighed portion of material passing the 7/8 in. sieve into the mold.
- 6.11 Use a spatula to move the material passing the 7/8 in. sieve around to fill voids **and completely cover** the aggregate particles retained on the 7/8 in. sieve. Do not rearrange the aggregate particles retained on the 7/8 in. sieve.
- 6.12 Use a spatula to spade around the inside perimeter of the mold to allow some of the material passing the 7/8 in. sieve to fill cavities around the edge.
- 6.13 Level the surface with the spatula. Do not push this layer down by hand or other means than those described above.
- 6.14 Lower the hammer and allow it to rest on the surface of the uncompacted lift.
- 6.15 Prepare the SCA for data collection **and use** the option that allows the SCA to shut the automatic tamper off when the total compacted energy of 750 ± 15 ft.-lb. is achieved for each lift. This must be achieved within **50 – 60 blows**.
- 6.16 Use the SCA to start the compactor. Compact the layer by dropping the 10-lb. rammer from a height of $18 \pm 1/2$ in.
- 6.16.1 When the number of blows is not within 50 – 60, discard the sample and make any necessary adjustments to the compactor or maintenance as recommended in Section 3 to achieve 750 ± 15 ft.-lb. within this allowable range of number of blows.
- 6.17 **After compaction of the first lift, raise the hammer and remove** material sticking to the ram face and **add it** to the material in the mold.
- 6.18 Use a spatula to scarify the surface of the lift just compacted. Do not dislodge aggregates from the previously compacted lift.
- 6.19 Repeat Sections 6.6 – 6.18 to compact the **second and third lift**.
- 6.20 Compact the fourth lift. Before adding the sample into the mold, use a flexible collar to extend the height of the mold collar to prevent any loss of material. Loss of material will change the mold height and moisture content. This will not produce an accurate moisture-density curve.

- 6.21 Ensure to use all the material to mold the sample. The surface of the fourth lift must be as free as possible from large aggregates.
- 6.22 Repeat Sections 6.6 – 6.16 to compact the fourth lift.
- 6.23 After the fourth lift has been compacted, fasten the mold and base plate to a finishing pedestal ensuring it is level.
- 6.24 Use a spatula or other suitable hand tool to dislodge material from the side of the mold that extends above the compacted surface. Lightly press this material into the surface.
- 6.24.1 Do not trim the compacted material with a straightedge. The compacted material will not completely fill the mold after compaction.
- 6.25 Use a small level to check the levelness of the specimen's surface.
- 6.25.1 Level the surface by placing the slide hammer on top of the specimen's surface and tap the bottom edge of the slide hammer with the plastic mallet. Repeat until the top of the specimen is level.
- 6.25.2 After the surface is level, apply ten blows to the top of the specimen with the slide hammer by slowly raising the weight to the drop height with minimal contact with the handle.
- 6.25.3 Ensure that the shaft of the slide hammer is maintained perpendicular to the specimen surface when dropping the 10 lb. weight.
- 6.26 Repeat Section 6.25.
- 6.27 Use a small level to check the levelness of the specimen's surface and tap the edge of the slide hammer if needed to level the sample one final time.
- 6.28 Remove the mold and base plate from the finishing pedestal.
- 6.29 Weigh the specimen in the mold to the nearest 0.001 lb. and measure the sample height with the micrometer dial assembly to the nearest 0.001 in. The height of the finished specimen is required to be 8 ± 0.250 in.
- 6.30 When the height does not meet this requirement, discard the molded sample and do not use this for the moisture-density curve. An additional sample is required to be weighed and compacted to replace it.
- 6.30.1 Use the equation in Section 8.5 to adjust the sample weight to achieve the required height and repeat Section 5.2 – Section 6.30 to compact a new sample.
- 6.31 Weigh and record the tare weight of a drying pan to the nearest 0.001 lb.
- 6.32 When the height meets the requirement, place the mold in the hydraulic press and extrude the specimen from the mold.
- 6.33 Place the extruded specimen in a drying pan and break it up without losing material. Place an identification tag with the loose material.
- 6.33.1 Loss of any material may result in calculation errors for the percent moisture content and the dry and wet densities.
- 6.34 Place the drying pan with the wet material in an oven at 230°F and dry to constant weight.

- 6.34.1 Constant weight is achieved when the weight loss is less than 0.1% of the sample weight after 4 hr. of drying.
- 6.35 Remove the drying pan with the oven dried material from the oven and allow to cool for a minimum of one hour.
- 6.36 Weigh the drying pan with the oven dried material. Subtract the tare weight from Section 6.31 to calculate the weight of the oven dried material.
- 6.37 Record to the nearest 0.001 lb.
- 6.38 Do not reuse material from compacted samples for the preparation of other compaction samples.
- 6.39 Repeat this procedure to compact each of the remaining samples.
-

7 MOISTURE-DENSITY CURVE

- 7.1 Calculate the wet density and percent moisture content for each mold using the equation from Section 8.5 and 8.6.
- 7.2 Use these results and the equation in Section 8.7 to calculate the dry density for each mold.
- 7.3 Graph the dry densities on the x-axis and the percent moisture contents on the y-axis, as shown in Figure 2.
- 7.3.1 The moisture-density curve must have results with two points below and two above the optimum moisture content.
- 7.3.2 Additional samples at different moisture contents will need to be molded until this is achieved.
- 7.4 Add a second order polynomial trendline to the data points.
- 7.5 Determine the R-square value for the fit of the data to the curve. The R-square must be greater than or equal to 0.9500.
- 7.6 When the R-square is not greater than 0.9500, mold additional samples to improve the fit of the data to the curve to achieve the minimum R-square value.
- 7.7 Verify the results from the molds with moisture contents that are the furthest away from the trendline. If the results are deemed accurate, mold additional samples at different moisture contents.

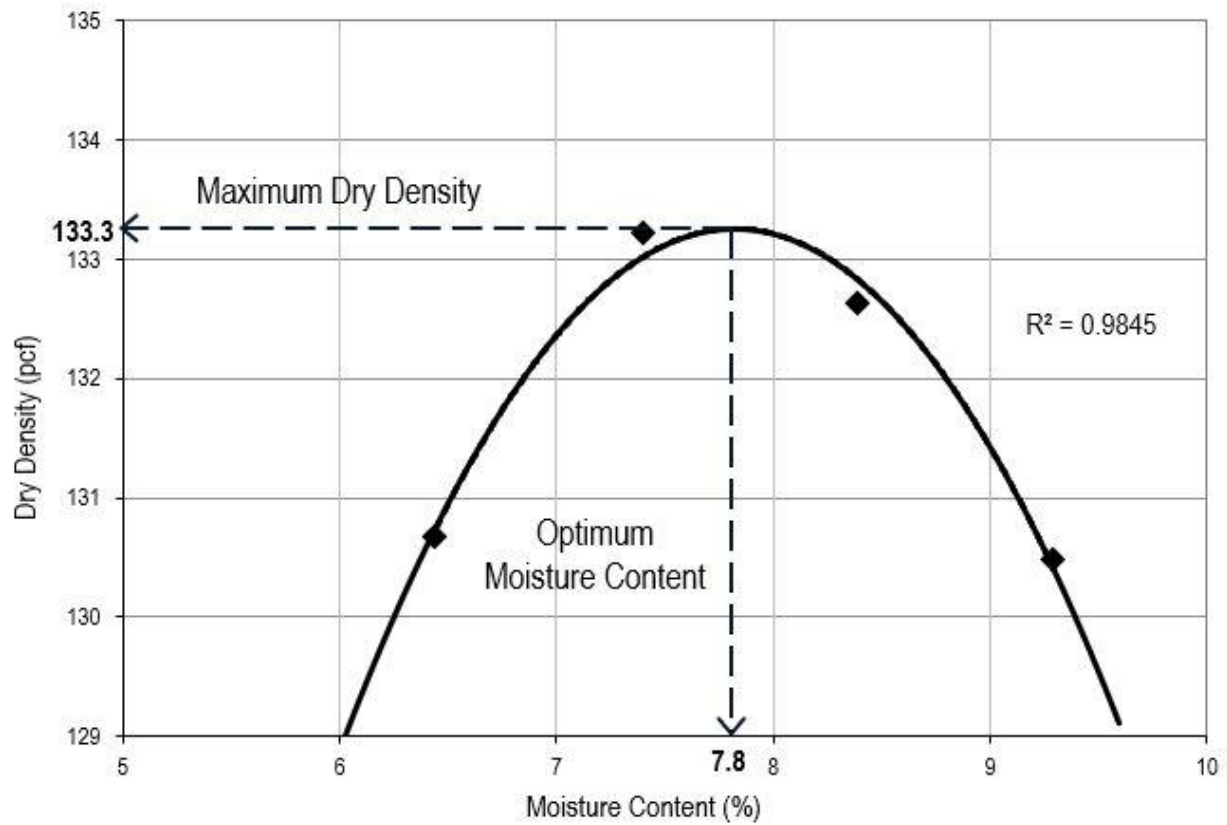

Figure 2
Example of a Moisture-Density Curve

8 CALCULATIONS

8.1 Use the following equation to calculate the individual weight retained on each sieve.

$$\text{Individual Weight Retained} = \left(\frac{\text{Individual \% Retained}}{100} \right) \times \text{Total Dry Weight}$$

8.2 Use the following equation to calculate the cumulative weight retained on each sieve.

$$\text{Cumulative Weight Retained} = \left(\frac{\text{Cumulative \% Retained}}{100} \right) \times \text{Total Dry Weight}$$

8.3 Use the following equation to calculate the weight of water to add to the sample.

$$\text{Weight of Water} = \left(\frac{\text{Moisture Content}}{100} \right) \times \text{Total Dry Weight}$$

8.4 Use the following equation to correct the weight of the sample to the required compacted mold height of 8 ± 0.250 in.

$$\text{Corrected Weight} = 8.000 \times \left(\frac{\text{Sample Weight}}{\text{Sample Height}} \right)$$

- 8.5 Use the following equation to calculate the Wet Density of the compacted mold.

$$\text{Wet Density} = \frac{W_T - W_M}{V_M}$$

Where:

W_T = weight of the mold and the compacted sample from Section 6.29.

W_M = weight of the mold.

V_M = volume of the mold, ft.³ (m³).

- 8.6 Use the following equation to calculate the Percent Moisture Content of the compacted mold.

$$\text{Percent Moisture} = 100 \times \left(\frac{W_W - W_D}{W_D} \right)$$

Where:

W_W = wet mass of the sample, lb.

W_D = oven dried mass of the molded sample, lb.

- 8.7 Use the following equation to calculate the Dry Density of the compacted mold.

$$\text{Dry Density} = 100 \times \left(\frac{\text{Wet Density}}{100 + \text{Percent Moisture}} \right)$$

Where:

Wet Density calculated from Section 8.5.

Percent Moisture calculated from Section 8.6.

9 REPORTING TEST RESULTS

- 9.1 Report the maximum dry density to the nearest 0.1 lb./ft.³.
- 9.2 Report the optimum moisture content to the nearest 0.1%.
- 9.3 Record the SCA data for the total energy, average drop height, average energy per blow, and the number of blows per lift for each compacted lift.

10 ARCHIVED VERSIONS

- 10.1 Archived versions are available.

Test Procedure for**TRIAXIAL COMPRESSION FOR DISTURBED SOILS AND
BASE MATERIALS****TxDOT Designation: Tex-117-E****Effective Date: January 2010**

1. SCOPE

- 1.1 This method determines the shearing resistance, water absorption, and expansion of soils and/or soil-aggregate mixtures.
 - 1.2 Use Part I when triaxial classification is required. Use Part II for flexible base materials and low to non-plastic soils.
 - 1.3 The values given in parentheses (if provided) are not standard and may not be exact mathematical conversions. Use each system of units separately. Combining values from the two systems may result in nonconformance with the standard.
-

2. DEFINITIONS

- 2.1 *Triaxial Test*—measures stresses in three mutually perpendicular directions.
 - 2.2 *Axial Load*—the sum of the applied load and the dead load (including the weight of the top porous stone, metal block and bell housing) applied along the vertical axis of the test specimen.
 - 2.3 *Lateral Pressure (Minor Principal Stress)*—the pressure supplied by air in the triaxial cell, applied in a radial or horizontal direction.
 - 2.4 *Axial (Major Principal Stress)*—the axial load divided by the average area of the cylindrical specimen.
 - 2.5 *Strain*—the vertical deformation of the specimen divided by the original height, often expressed as a percentage.
 - 2.6 *Mohr's Diagram*—a graphical construction of combined principal stresses in static equilibrium.
 - 2.7 *Mohr's Failure Cycle*—a stress circle constructed from major and minor principal stresses of the specimen at failure.
 - 2.8 *Mohr's Failure Envelope*—the common tangent to a series of failure circles constructed from different pairs of principal stresses required to fail the material. The envelope is
-

generally curved, with its curvature depending on the factors related to the characteristics of the material.

3. APPARATUS

- 3.1 *Apparatus* used in Tex-101-E, Tex-113-E, and Tex-114-E.
- 3.2 *Triaxial cells for base material*, lightweight stainless steel cylinders with 6.75 in. (171.5 mm) inside diameter (ID) and 12 in. (304.8 mm) height, fitted with standard air valve and tubular rubber membrane.
- 3.3 *Triaxial cells for subgrade*, lightweight stainless steel cylinders with 4.5 in. (114.3 mm) ID and 9 in. (228.6 mm) height, fitted with standard air valve and tubular rubber membrane.
- 3.4 *Aspirator or other vacuum pump*.
- 3.5 *Air compressor*.
- 3.6 *Automated load frame or screw jack press*.
- 3.7 *Pressure regulator, gauges, and valves*, to produce lateral pressure in curing and testing.
- 3.8 *Equipment to measure deformation of specimen*, accurate to 0.001 in. (0.025 mm).
- 3.9 *Proving ring* (for use with screw jack press).
- 3.10 *Load cell*, 10K (for use with automated load frame).
- 3.11 *Circumference measuring device*, accurate to 0.05 in. (1.0 mm).
- 3.12 *Lead weights*, for surcharge loads.
- 3.13 *Curing pans*, at least 2 in. (51 mm) deep, with porous plates.
- 3.14 *Filter paper*, medium flow porosity, such as VWR No. 413.
- 3.15 *Non-porous paper discs*, 6 in. (150 mm) diameter, Gilson MSA-121 or equivalent.
-

4. TEST RECORD FORMS

- 4.1 Record test data on:
- [Form Tx113,4](#), “Moisture-Density Relations of Base Material & Sand or Subgrade & Embankment Soils” and “Moisture-Density Mold Information Sheet,”
 - [Form 1964](#), “Triaxial Compression Test Capillary Wetting Data,” and
 - [Form 1062](#), “Triaxial Test Data Sheet” (use with screw jack press) or [Form Tx117](#), “Triaxial Compression Tests” (use with automated compression machine).
-

PART I—STANDARD TRIAXIAL COMPRESSION TEST

5. PROCEDURE

- 5.1 Prepare all materials in accordance with Tex-101-E, Part II.
- 5.2 Determine optimum water content and maximum dry density of the material in accordance with Tex-113-E for base material and Tex-114-E for subgrade, embankment, and backfill.
- 5.3 Mold seven specimens at optimum moisture and maximum dry density in accordance with Tex-113-E for base and sub-base materials; mold six specimens at optimum moisture and maximum dry density in accordance with Tex-114-E for subgrade, embankment, and backfill materials.
- 5.3.1 These specimens should be 6 in. (152.4 mm) in diameter \pm 0.0625 in. (1.6 mm) and 8 in. (203.2 mm) in height \pm 0.250 in. (6.4 mm) or 4 in. (101.6 mm) in diameter \pm 0.0156 in. (0.4 mm) and 6 in. (152.4 mm) in height \pm 0.0026 in. (0.07 mm) using a straight edge to strike off the top and bottom.
- 5.3.2 These specimens should be wetted, mixed, molded, and finished as nearly identical as possible.
- 5.4 Record the weight of the compacted specimens on Form Tx113,4, “Moisture-Density Relations of Base Material & Sand or Subgrade & Embankment Soils” and “Moisture-Density Mold Information Sheet.”
- 5.5 Extrude the specimens from the molds and identify each test specimen by laboratory number and specimen number.
- 5.6 Immediately after extruding the specimens from the molds, enclose the specimens in triaxial cells, with porous stones on top and bottom and a non-porous paper disc between the top of the specimen and the top porous stone to prevent moisture from traveling from the specimen into the porous stone. Allow all the specimens to remain undisturbed at room temperature until the entire set of test specimens has been molded.
- 5.7 After all specimens in the set have been molded, remove the triaxial cells, leaving the top and bottom porous stones in place. Dry the specimens according to the type of material described below.
- 5.7.1 *For Flexible Base Materials and Select Granular Soils with Little or No Tendency to Shrink:*
- 5.7.1.1 Place specimens in the oven and remove one third of the molding moisture content at a temperature of 140°F (60°C). Record the weight after drying.
- 5.7.1.2 Allow the specimens to return to room temperature.

- 5.7.2 *For Very Plastic Clay Sub-Grade Soils that Crack Badly if Subjected to Large Volume Changes during Shrinkage:*
- 5.7.2.1 Air dry these soils at room temperature, inspecting specimens frequently by looking at the sides of the specimens and raising the top porous stones to examine the extent of cracking at the top edges of the specimens.
- 5.7.2.2 When these cracks have formed to a depth of approximately 1/4 in. (6.4 mm), replace the triaxial cell and prepare the specimens for capillary wetting.
- 5.7.3 *For Moderately Active Soils that Might Crack Badly if Placed in an Air Dryer for the Full Curing Time:*
- 5.7.3.1 Dry at 140°F (60°C) and check frequently for the appearance of shrinkage cracks.
- 5.7.3.2 If cracks appear, examine the extent of cracking as described above and allow some air-drying at room temperature during the cooling period before enclosing specimens in cells.
- 5.8 Prepare the specimens for capillary wetting.
- 5.8.1 Do not change the porous stones or remove them until the specimens have been tested.
- 5.8.2 Weigh each specimen and its accompanying stones and record the mass.
- 5.8.3 Cut a piece of filter paper to approximately 12 × 20 in. (300 × 508 mm), fold into 5 × 20 in. (127 × 508 mm), and make several slits perpendicular to the folded edge with scissors. These cuts will prevent any restriction by the paper.
- 5.8.4 Unfold the filter paper and wrap it around the specimen and stones so the cuts are parallel with the length of the specimen, allowing the bottom of the paper to be near the bottom of the bottom porous stone, and fasten with a piece of tape.
- 5.8.5 Replace cell by applying a partial vacuum to the cell, deflating the rubber membrane, then place the cell over the specimen and release the vacuum.
- 5.9 Transfer the specimens to a temperature controlled environment and place them into the rectangular pans provided for capillary wetting. Adjust the water level on the lower porous stones to approximately 0.5 in. (12.5 mm) below the bottom of the specimens. Add water later to the pans, as necessary, to maintain this level. (See Figure 1.)
- 5.10 Connect each cell to an air manifold and open the valve to apply a constant lateral pressure of 1 psi (6.9 kPa). Maintain this constant pressure throughout the period of absorption.
- 5.11 Place a suitable vertical surcharge load (which will depend upon the proposed use or location of the material in the roadway) on the top porous stone. (See Table 1.) When determining the mass for the surcharge, include the mass of the top porous stone as part of the surcharge mass.

- 5.12 Subject all flexible base materials and soils with plasticity index of 15 or less to capillary absorption for 10 days. Use a period of days equal to the plasticity index of the material for sub-grade soils with PI above 15. Keep the specimens at $77 \pm 9^\circ\text{F}$ ($25 \pm 5^\circ\text{C}$) during the period of capillary absorption.
- 5.13 Disconnect the air hose from the cell and remove the surcharge weight. Use a vacuum and deflate the rubber membrane to aid in removing the cell from specimens and discard filter paper. If any appreciable material clings to paper, carefully press it back into the available holes along the side of the specimen.
- 5.14 Weigh the specimens and record as total mass after capillary absorption. Note that the wet mass of the stones is obtained after the specimens are tested. Record on Form 1964.
- 5.15 Measure the circumference of each specimen by means of the metal measuring tape. Measure the height of the specimen including the stones, and enter on the data sheet as height in/out capillarity. Record the height of each stone.
- 5.16 Ready the specimen to be tested by replacing the triaxial cell to eliminate any moisture loss from the specimen and then releasing the vacuum. When a specimen is designated to be tested at zero lateral pressure, remove the cell just before testing. It is important to keep the correct identification on the specimens at all times because weights, measurements, test values, and calculations are determined for each individual specimen.
- 5.17 Test the specimens in compression while they are being subjected to their assigned lateral pressure. The usual lateral pressures used for a series of tests are 0 psi (0 kPa), 3 psi (20.7 kPa), 5 psi (34.5 kPa), 10 psi (69.0 kPa), 15 psi (103.5 kPa), and 20 psi (138.0 kPa). In cases where the load or stress is high, 175–180 psi (1207–1241 kPa), for the specimen tested at 15 psi (103.5 kPa) lateral pressure, use 7 psi (48.3 kPa) instead of 20 psi (138.0 kPa) for the last specimen.
- 5.18 Operate the automated load frame (or screw jack press) at a rate of $2.0 \pm 0.3\%$ strain per minute.
- 5.19 *Automated Load Frame:*
- 5.19.1 Lower the load frame bottom platen to allow for adequate room to place the specimen in the load frame. Ensure that load frame platform is clean of debris that may cause the specimen to sit irregularly.
- Note 1**—Follow the instruction manual furnished with the load frame and data acquisition software for specifics on the operation of the load frame. This is essential, due to the fact that various load frame models and brands are in standard use by the Department.
- 5.19.2 Carefully transfer the specimen with porous stones and triaxial cell in place to the bottom platen of the load frame. For specimens broken at 0 psi lateral pressure, a pan may be placed beneath the specimen to catch any small fragments that may fall off the specimen during testing.
- 5.19.3 Place the end cap, with ball bearing, onto the top porous stone.

- 5.19.4 Raise the crossbar or lower the bottom platen to a height that allows for movement of the specimen without causing damage to or disturbing the specimen.
- 5.19.5 Shift the end cap and porous stone laterally to bring the ball bearing directly over the vertical axis of the specimen. Adjust the specimen in the load frame such that the ball bearing is centered with the load cell button and the axial load will be applied along the vertical axis of the specimen.
- 5.19.6 Tare the load cell, using the data acquisition software.
- 5.19.7 Raise the bottom platen so that the load cell is in contact with the ball bearing. The ball bearing should be seated in the button of the load cell.
- 5.19.8 Apply a vertical load of approximately 1/2–1 psi (15–30 lb.)
- 5.19.9 Connect the air line, with electronic pressure sensor, to the triaxial cell and apply the designated lateral pressure, as defined in Section 5.17, to the specimen. Allow the pressure to stabilize prior to proceeding. (The lateral pressure applied by the air will tend to change the initial load cell reading.)
- 5.19.10 Once the lateral pressure has stabilized, zero the deformation gauge, begin testing the specimen in compression, and start data acquisition.
- 5.19.11 Initiate the software and load frame testing sequence.
- 5.19.12 Manually or via the testing software, record the initial load cell reading when data acquisition begins.
- 5.19.13 Record load and specimen deformation in 0.02 in. (0.5 mm) increments.
- 5.19.14 Follow the data acquisition software instructions to monitor test progress.
- 5.19.15 Continue readings until failure has occurred as defined in Section 5.22.
- 5.20 *Screw Jack Press (See Figure 2):*
- 5.20.1 Lower the load frame platen far enough to have room to place the specimen, loading blocks, and deformation measuring equipment in the press.
- 5.20.2 Center the specimen with upper and lower loading blocks in place in the load frame. Determine if the deformation gauge will compress or extend during testing and set the dial stem accordingly. Set the dial of the strain gauge to read zero.
- 5.20.3 Next, set the bell housing, if used, over the deformation gauge and adjust so that it does not touch the gauge or its mounting.
- 5.20.4 Shift the bell housing laterally to bring the ball directly over the vertical axis of the specimen in order to apply the compressive force along the vertical axis of the test specimen.

- 5.20.5 Raise the platen by means of the motor, align, and seat the ball on the bell housing into the socket in the proving ring.
- 5.20.6 Apply just enough pressure to obtain a perceptible reading on the proving ring gauge (not to exceed 5 lb.)
- 5.20.7 Read the deformation gauge and record as deformation under dead load.
- 5.20.8 Connect the air line to the triaxial cell and apply the designated lateral pressure, as defined in Section 5.17, to the specimen. Allow the pressure to stabilize prior to proceeding.
- Note 2**—In testing specimens with aggregates, the slipping and shearing of aggregates will cause temporary decreases in proving ring readings.
- 5.20.9 The lateral pressure applied by the air will tend to change the initial proving ring and deformation gauge readings. Start the motor momentarily to compress the specimen until the deformation gauge reads the same as the reading obtained in Section 5.20.7.
- 5.20.10 Record the proving ring reading.
- 5.20.11 Turn the motor on and read the proving ring dial in 0.02 in. (0.5mm) increments.
- 5.20.12 Continue the test until failure has occurred as defined in Section 5.22.
- 5.21 Continue reading until 0.60 in. (15.2 mm) of deformation is reached or failure has occurred. After 0.60 in. (15.2 mm) of deformation the cross sectional area of the specimen has increased so that the subsequent small increase in load readings is little more than the increase in tension of the membrane acting as lateral pressure.
- 5.22 Failure is reached when the proving ring dial or load cell readings remain constant or decrease with increased deformation.
- 5.23 The above procedure also applies to an unconfined specimen, except that no air or axial cell is used. For materials that contain a large amount of aggregate, test two specimens at zero lateral pressure. Use average of test results unless large rocks appear to have created point bearing; in this case use highest value.
- 5.24 Remove the cell and stones from the specimen over a flat, tared drying pan. Use a spatula to clean the material from the inside of cell and stones. Break up the specimen taking care to lose none of the material and place the identification tag in the tray.
- 5.25 Dry material to constant mass at a temperature of 230°F (110°C) and determine the dry mass. Determine and record the moisture content of the entire specimen after breaking, in accordance with Tex-103-E.
- 5.26 Clean the damp stones and then dry at 140°F (60°C) to constant mass.

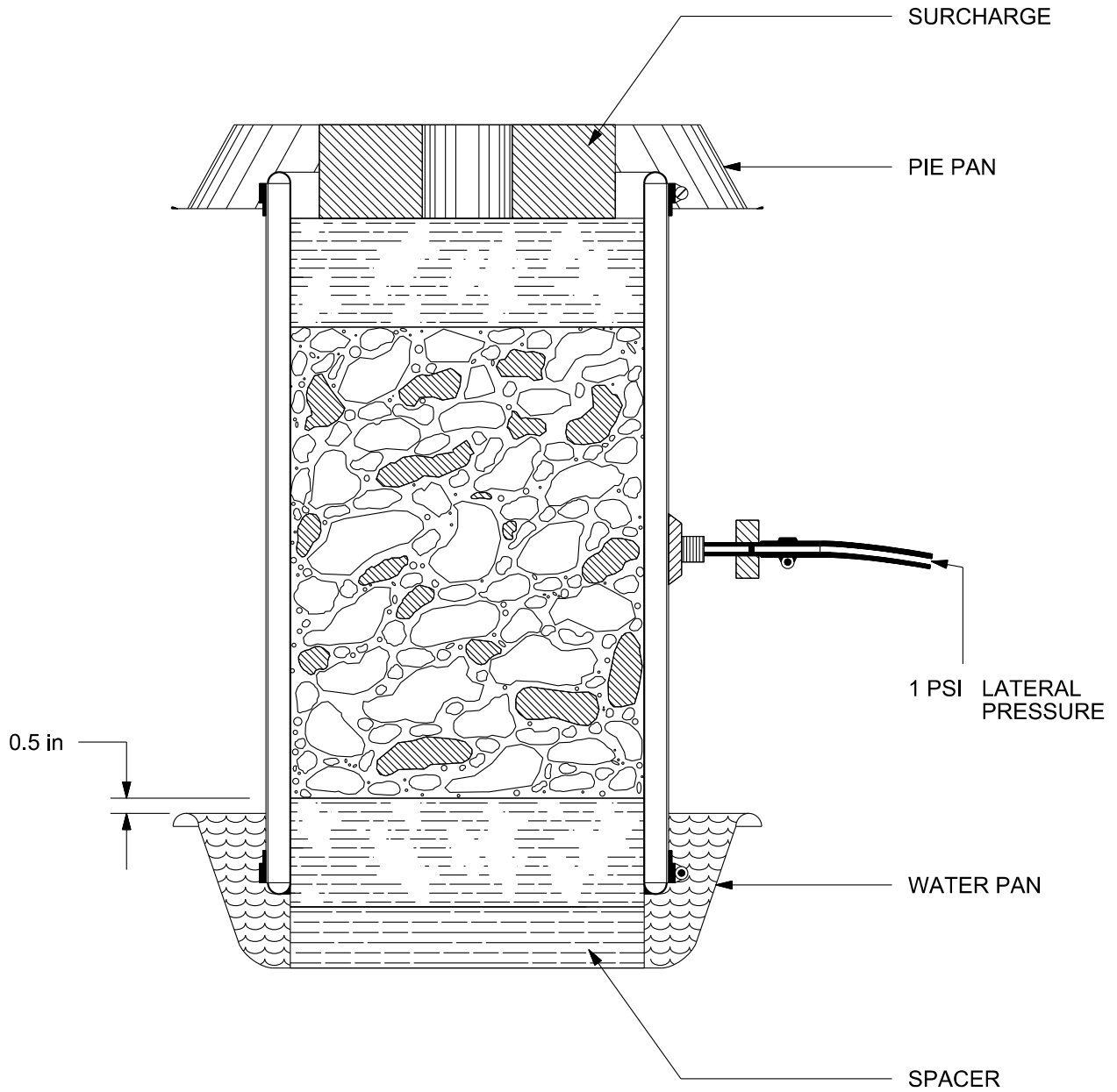

Figure 1—Schematic Arrangement for Capillary Wetting

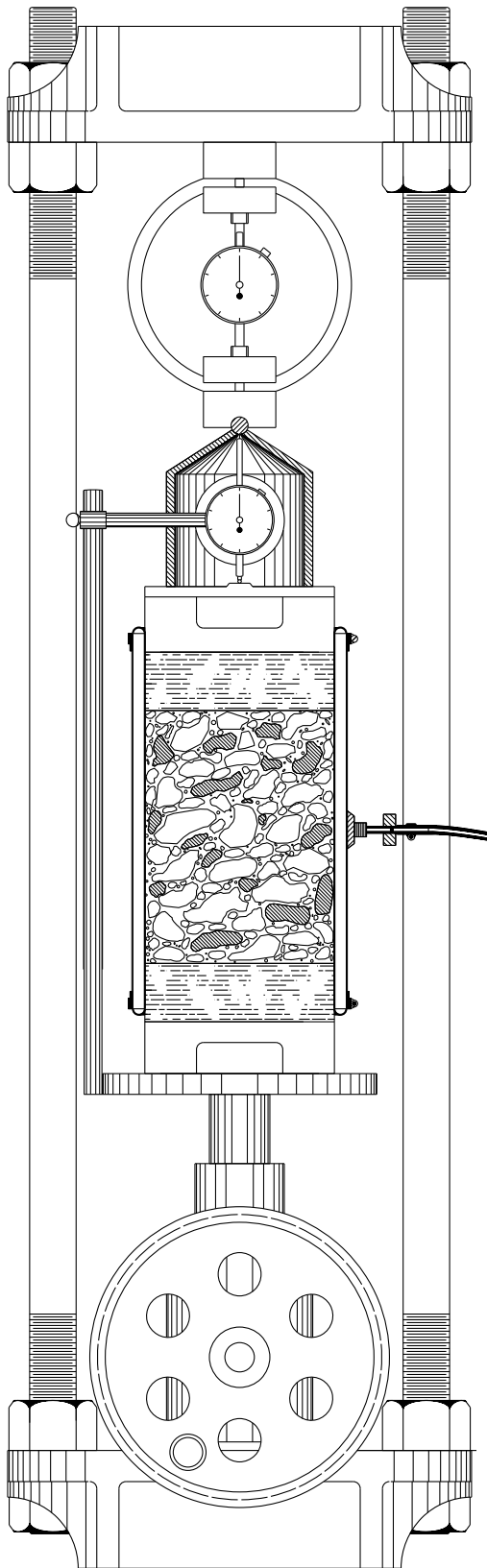

Figure 2—Assembly for Screw Jack Press

Table 1—Vertical Surcharge Load

Mold Diameter	Flexible Base	Sub-grade Soil
6 in. (152 mm)	14.1 lb. (6.4 kg)	28.3 lb. (12.8 kg)
4 in. (102 mm)	N/A	12.6 lb. (5.7 kg)

6. CALCULATIONS

6.1 Use the electronic worksheets contained in Form Tx113,4 and Form 1062 (use with screw jack press) or Form Tx117 (use with automated compression machine) to calculate and record the following:

6.2 Calculate dry density (D_D) in lb./ft.³ (pcf):

$$D_D = W_D / V$$

Where:

V = volume of compacted specimen, ft.³ (m³)

W_D = dry mass of specimen, lb. (kg).

6.3 Calculate the percent molding moisture (M_M):

$$M_M = [100(W_W - W_D) / W_D]$$

Where:

W_W = wet mass of specimen, lb. (kg)

6.4 Calculate the percent of volumetric swell (V_S):

$$V_S = 100(V_A - V) / V$$

Where:

V_A = volume of specimen after capillary absorption, ft.³ (m³).

6.5 Calculate the percent moisture in the specimen after capillarity (M_C):

$$M_C = 100(W_A - W_B - W_D) / W$$

Where:

W_A = wet mass of specimen and stones after absorption, lb. (kg)

W_B = wet mass of stones, lb. (kg)

W_D = correct oven-dry mass of specimen, lb. (kg).

- 6.6 Calculate the percent moisture in the specimen before capillarity (M_B):

$$M_B = 100(W_C - W_S - W_D) / W_D$$

Where:

W_S = dry mass of stones, lb. (kg)

W_C = mass of specimen and stones before capillarity, lb. (kg).

- 6.7 Calculate the corrected vertical unit stress in psi (kPa). A correction is necessary because the area of the cross-section increases as the specimen is reduced in height. Assume that the specimen deforms at constant volume.

$$S = 100(d / h) = \text{percent strain}$$

Where:

d = total vertical deformation at a given instant, in. (mm), by deformation gauge

h = the height of the specimen, in. (mm), measured after specimen is removed from capillarity.

- 6.8 Calculate the corrected vertical unit stress (p):

$$p = 9.81 [P(1 - S / 100) / A], \text{ in kPa} \quad \text{or} \quad p = P[(1 - S / 100) / A], \text{ in psi}$$

Where:

A = the end area of the cylindrical specimen at the beginning of test, in.² (mm²)

P = the total vertical load on the specimen at any given deformation expressed in lb. (g).
It is the sum of the applied load measured by the proving ring plus the dead mass of the upper stone, loading block, and dial housing.

7. GRAPHS AND DIAGRAMS

- 7.1 Use the electronic worksheets contained in Form Tx113,4 and Form 1062 (use with screw jack press) or Form Tx117 (use with automated compression machine) to plot the following.
- 7.2 Plot the moisture-density curve shown in Tex-113-E, Figure 1.
- 7.3 Plot the stress-strain diagram as shown in Figure 3, when requested.
- 7.4 Construct the Mohr's Diagram of stress upon coordinate axes in which ordinates represent shear stress and abscissas represent normal stress, both expressed as psi (kPa) to the same scale. (See Figure 4.)
- L = Minor principal stress which is the constant lateral pressure applied to the specimen during an individual test.
 - V = The major principal stress which is the ultimate compressive strength or the highest value of p determined at the given lateral pressure.

- 7.5 Show each individual test by one stress circle.
- Plot L and V on the base line of normal stress.
 - Locate the center of each circle a distance of $(V + L)/2$ from the origin and construct a semi-circle with its radius equal to $(V - L)/2$ intersecting the base line at V and L .
 - Repeat these steps for each specimen tested at different lateral pressures to provide enough stress circles to define the failure envelope on the Mohr's diagram.
- 7.6 Draw the failure envelope tangent to all of the stress circles. Since it is practically impossible to avoid compacting an occasional specimen that is not identical with the other specimens in the same set, disregard any stress circle that is obviously out of line when drawing the tangent line.

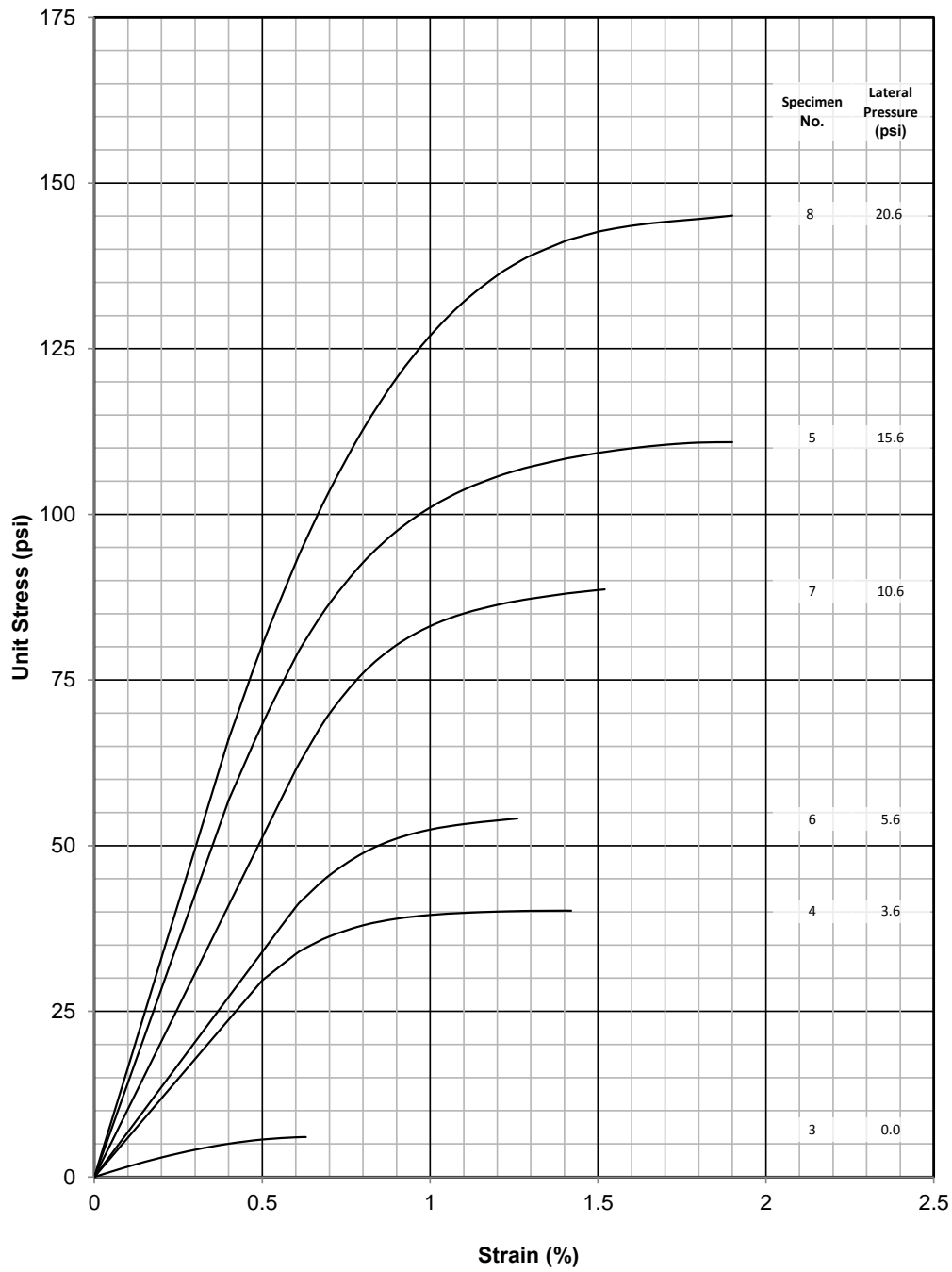

Figure 3—Stress-Strain Diagram

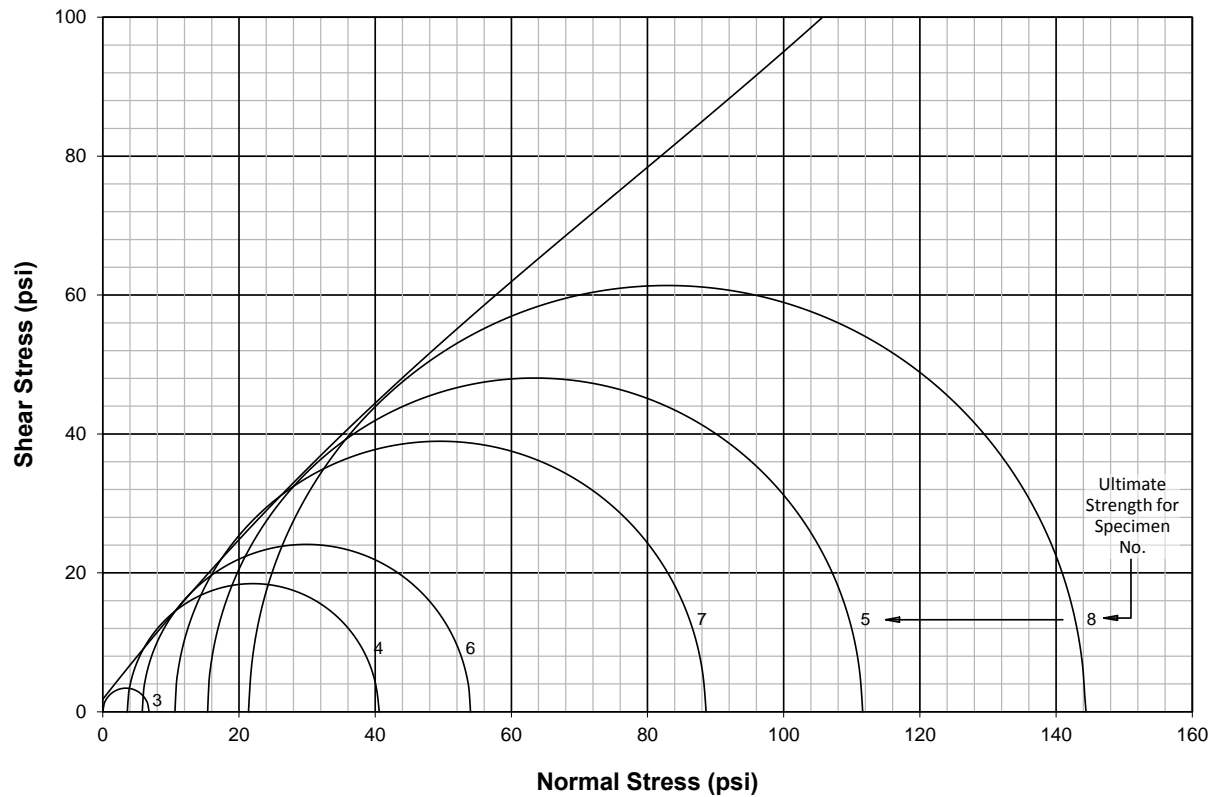

Figure 4—Mohr's Diagram

8. CLASSIFICATION OF MATERIAL

- 8.1 Use Form Tx117 to classify the material to the nearest one-tenth of a class.
- 8.2 When the envelope of failure falls between class limits, select the critical point or weakest condition on the failure envelope.
- 8.3 Measure the vertical distance down from a boundary line to the point to obtain the exact classification (3.7) as shown in Figure 5.

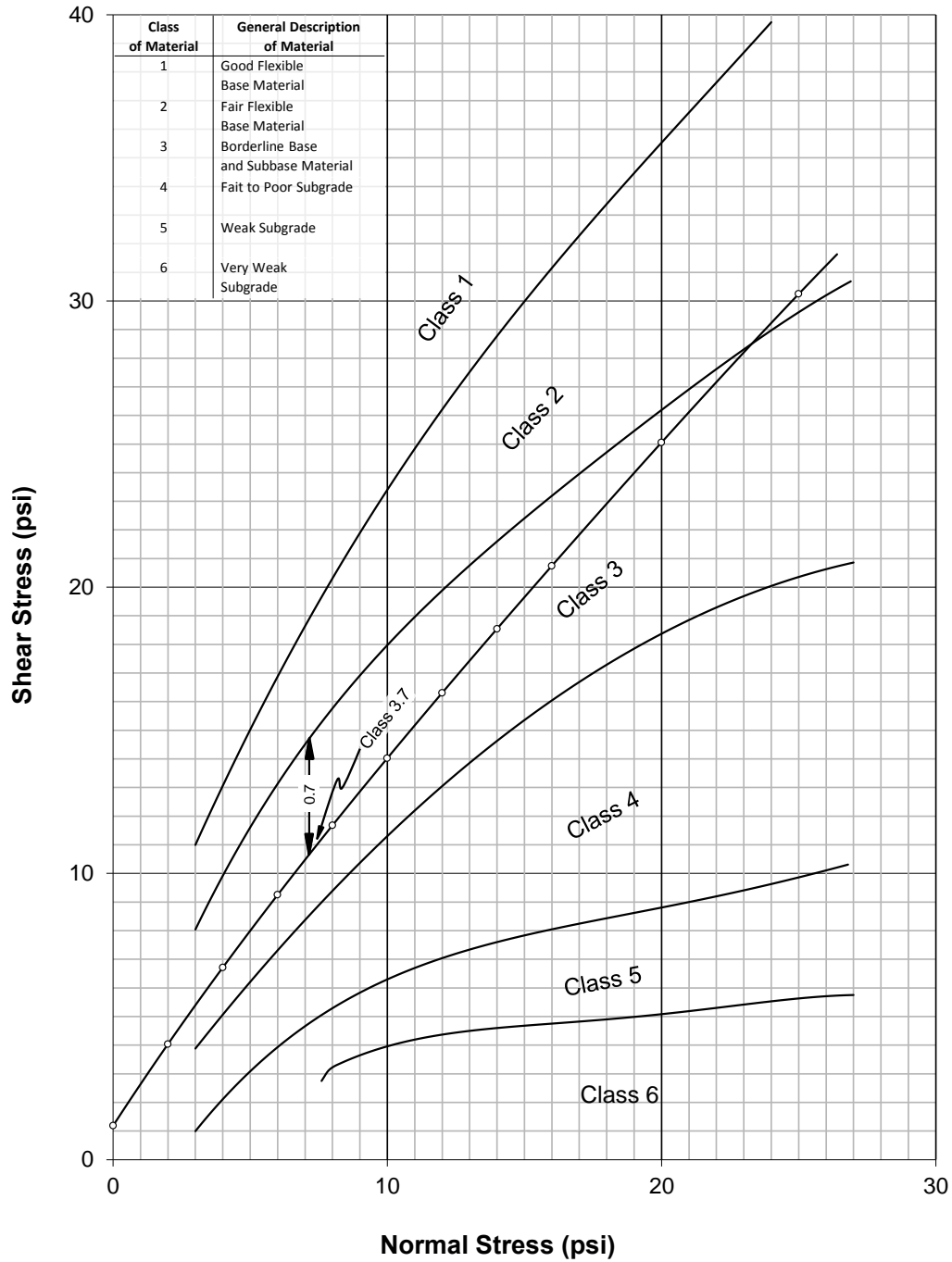

Figure 5—Chart for Classification of Sub-Grade and Flexible Base Material

9. TEST REPORT

9.1 Report the soil constants, grading, and wet ball mill value for the base material. Summarize test results on Form Tx117.

PART II—ACCELERATED METHOD FOR TRIAXIAL COMPRESSION OF SOILS

10. SCOPE

- 10.1 This accelerated procedure is based on a correlation with Part I, performed on a large number of different types of materials. Generally, use the accelerated test to control the quality of base materials with low absorption in group (d) during stockpiling. In such cases, roadway samples will not be considered representative.

11. PROCEDURE

- 11.1 Group the materials into one of the following five general types of materials:
- A—Fine granular materials with plasticity index less than 5.
 - B—Very low swelling soils with plasticity index of 5 through 11.
 - C—Swelling sub-grade soils with plasticity index of 12 or more.
 - D—Flexible base with or without recycled materials.
 - E—Combination soil types.
- 11.2 Prepare all materials in accordance with Tex-101-E, Part II.
- 11.3 Determine optimum moisture content and maximum dry density of the material in accordance with Tex-113-E for base material and Tex-114-E for subgrade, embankment, and backfill.
- 11.4 Molded specimens should be 6 in. (152.4 mm) in diameter \pm 0.0625 in. (1.6 mm) and 8 in. (203.2 mm) in height \pm 0.250 in. (6.4 mm) or 4 in. (101.6 mm) in diameter \pm 0.0156 in. (0.4 mm) and 6 in. (152.4 mm) in height \pm 0.0026 in. (0.07 mm) using a straight edge to strike off the top and bottom.
- 11.5 Record data on Form Tx113,4.
- 11.6 Follow the correct procedure for the specimen soil type, as shown below
- 11.6.1 *Group A—Fine Granular Materials with Plasticity Index Less Than 5:*
- 11.6.1.1 Mold six specimens 6 in. (152.4 mm) in diameter and 8 in. (203.2 mm) in height at the optimum moisture and density in accordance with Tex-113-E.
- 11.6.1.2 Cover the specimen (with stones in place) with a triaxial cell immediately after removing from mold and allow to set for 24 ± 1 hr. undisturbed at room temperature.
Note 3—Do not dry or subject specimens to capillary absorption.
- 11.6.1.3 Test the specimens at the usual lateral pressures.

- 11.6.1.4 Calculate unit stress, plot diagrams, and classify material.
- 11.6.2 *Group B—Very Low Swelling Soils with Plasticity Index of 5 through 11:*
- 11.6.2.1 Compact a set of six identical specimens at the optimum moisture and density condition in accordance with Tex-113-E.
- 11.6.2.2 Use filter paper, lead surcharge weight, and air pressure for lateral support and subject the specimens to capillary absorption overnight as described in Part I, Sections 5.8–5.12.
- 11.6.2.3 The next morning, remove filter paper and test the specimens at the usual lateral pressure shown above. Calculate unit stress, plot diagrams, and classify material.
- 11.6.3 *Group C – Swelling Sub-Grade Soils, Plasticity Index of 12 or More:*
- 11.6.3.1 Obtain the plasticity index and hygroscopic moisture of these soils in advance of molding specimens.
- 11.6.3.2 Calculate the Percent Molding Moisture:
Percent Molding Moisture = $(1.4 \times \text{optimum moisture}) - 2.2$
- 11.6.3.3 Obtain the desired molding density from the following expression:
Molded Dry Density = $\text{Optimum dry density (from Section 11.2)} / [1 + (\% \text{ volumetric swell} / 100)]$
- 11.6.3.4 To determine the percent volumetric swell to be expected, use average condition in chart shown in Figure 6. It is important to modify the percent volumetric swell by multiplying by percent soil binder divided by 100 to obtain the percent volumetric swell to be expected.
- 11.6.3.5 Use the moisture content (Section 11.6.3.2), adjusted if necessary, and adjust the blows per layer to obtain the desired density (Section 11.6.3.3). Where this moisture content is too great to permit the desired density, reduce the molding water slightly (usually about 1%) and continue molding. Mold six specimens, in accordance with Tex-114-E, at the water content established for the desired density. The specimens, being in capillarity overnight, will pick up the moisture that was left out.
- 11.6.3.6 When the six specimens have been molded, put them to capillary absorption (as in Part I) overnight. Test at the usual lateral pressures and classify.

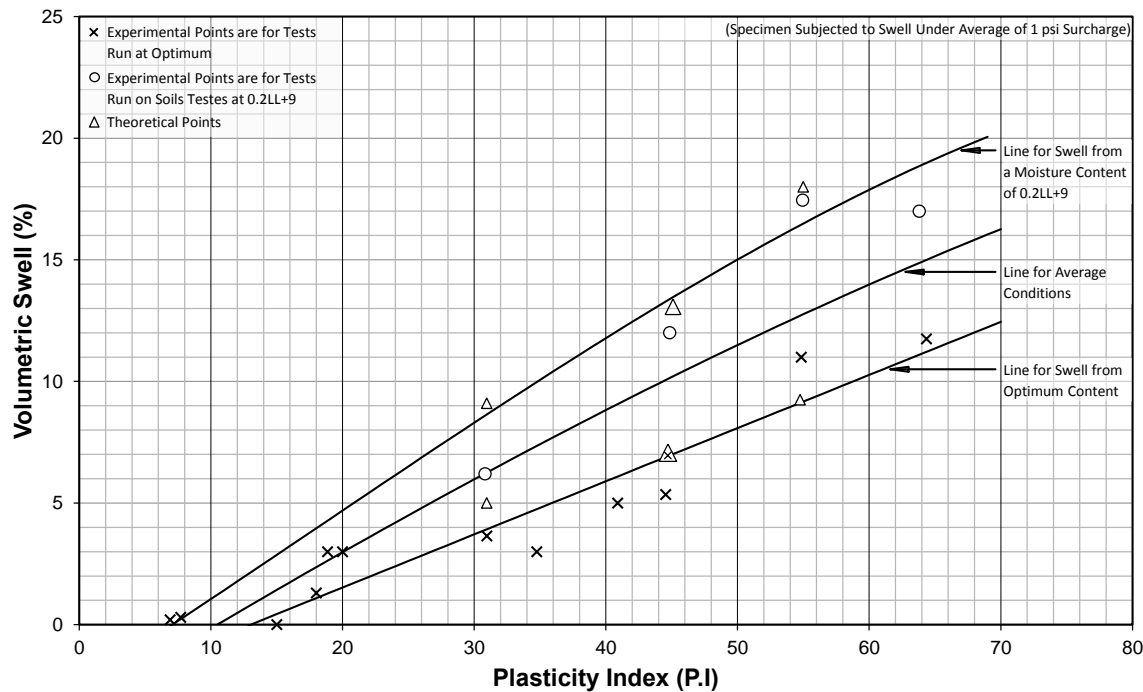

Figure 6—Interrelationship of PI and Volume Change

11.6.4 *Group D – Flexible Base With or Without Recycled Materials:*

11.6.4.1 Mold specimens at optimum moisture and maximum dry density in accordance with Tex-113-E.

11.6.4.2 All specimens should be wetted, mixed, molded, and finished as nearly identical as possible.

11.6.4.3 Identify each test specimen by laboratory number and specimen number.

11.6.4.4 Immediately after extruding the specimens from the molds, enclose the specimens in triaxial cells, with porous stones on top and bottom and non-porous paper discs between the specimen and porous stones to prevent moisture from traveling from the specimen into the porous stone.

11.6.4.5 Allow specimens to set 24 ± 1 hr. undisturbed at room temperature.

Note 4—Do not air dry or subject specimens to capillary absorption.

11.6.4.6 Test specimens in compression in accordance with Section 5.19 when using an automated load frame or Section 5.20 when using a screw jack press. Test three specimens at 0 lateral confinement, three specimens at 3 psi (20.6 kPa) lateral confinement and three specimens at 15 psi (103.4 kPa) lateral confinement.

11.6.4.7 Continue reading until 0.60 in. (15.2 mm) of deformation is reached or failure has occurred. After 0.60 in. (15.2 mm) of deformation the cross sectional area of the

specimen has increased so that the subsequent small increase in load readings is little more than the increase in tension of the membrane acting as lateral pressure.

- 11.6.4.7.1 Failure is achieved when the proving ring dial or load cell readings remain constant or decrease with increased deformation.
- 11.6.4.7.2 The above procedure also applies to an unconfined specimen, except that no air or triaxial cell is used. For materials that contain a large amount of aggregate, test two specimens at zero lateral pressure. Use average of test results unless large rocks appear to have created point bearing; in this case use highest value.
- 11.6.4.8 Remove the cell and stones from the specimen over a flat, tared drying pan. Use a spatula to clean the material from the inside of cell and stones. Break up the specimen taking care to lose none of the material and place the identification tag in the tray.
- 11.6.4.9 Dry material to constant mass at a temperature of 230°F (110°C) and determine the dry mass. Determine and record the moisture content of the entire specimen after breaking, in accordance with Tex-103-E.
- 11.6.4.10 Clean the damp stones and then dry at 140°F (60°C) to constant mass.
- 11.6.4.11 Calculate and record dry density (D_D) in lb./ft.³ (pcf) on Form Tx113,4 for each specimen:

$$D_D = W_D / V$$

Where:

V = volume of compacted specimen, ft.³ (m³)

W_D = dry mass of specimen, lb. (kg).

- 11.6.4.12 Calculate and record the percent molding moisture (M_M) on Form Tx113,4 for each specimen:

$$M_M = [100(W_W - W_D) / W_D]$$

Where:

W_W = wet mass of specimen, lb. (kg).

- 11.6.4.13 The percent molding moisture of the individual specimens calculated in Section 11.6.4.12 must be within 0.3 percentage points of the optimum moisture content determined by Tex-113-E and the dry density of the individual test specimens calculated in Section 11.13 must be within 1.0 pcf (16.0 kg/m³) of the maximum dry density determined by Tex-113-E. Specimens not meeting these tolerances may be used in Section 11.6.4.14 only if their strength is within 10 psi of the other test specimens broken at the same lateral confinement.

- 11.6.4.14 Average and record the strengths for each state of confinement on Form Tx117. A minimum of two samples per lateral confinement must be used to determine the average strength.

11.6.5 *Group E – Combination Soil Types:*

11.6.5.1 This group includes all materials with enough soil binder to separate the aggregate particles or overfill the voids of the compacted specimen. For example, if the material is a clayey gravel with high plasticity:

- Treat the material as a swelling soil.
- Allow the material to soak a minimum of 12 hours as in the case of aggregate materials.

11.6.5.2 Note that the total swelling is figured only for that part passing the No. 40 (425 µm) sieve. Other combinations must be recognized and tested in the proper group.

11.6.5.3 Mold six specimens at optimum moisture and maximum dry density in accordance with Tex-114-E for subgrade, embankment, and backfill materials.

11.6.5.4 Subject all specimens to overnight capillarity, test, and classify.

11.6.5.5 When testing aggregate materials under Part II where classification is required:

11.6.5.5.1 Test two specimens at 0 psi (0 kPa).

11.6.5.5.2 Test the others at 3 psi (20.7 kPa), 5 psi (34.5 kPa), 10 psi (69.0 kPa), and 15 psi (103.4 kPa).

11.6.5.5.3 Average the result of the zero lateral pressure tests as one value.

11.6.5.5.4 Classify fine grain soils using lateral pressures of 0 psi (0 kPa), 3 psi (20.7 kPa), 5 psi (34.5 kPa), 10 psi (69.0 kPa), 15 psi (103.4 kPa).

12. REPORTING TEST RESULTS

12.1 The reports and forms are the same as given in Part I of this procedure.

13. GENERAL NOTES

13.1 Wetted stabilized materials taken from the roadway during construction should be screened over a 1/4 in. (6.3 mm) sieve at the field moisture content without drying.

13.1.1 Each of these two sizes is mixed for uniformity and weighed.

13.1.2 Specimens are then weighed and recombined to produce multiple identical specimens with the received gradation.

13.1.3 Moisture can be adjusted in each specimen by adding water to the material or removing from the material by a fan, as needed.

- 13.1.4 See the appropriate test method (listed below) for testing wetted stabilized materials taken from the roadway during construction:
- Tex-120-E, “Soil-Cement Testing”
 - Tex-121-E, “Soil-Lime Testing”
 - Tex-127-E, “Lime Fly-Ash Compressive Strength Test Methods”
- 13.2 In any event, the stabilized material should not be completely air-dried.
- 13.3 When molding a set of preliminary specimens for testing lime stabilized sub-grades and base materials, refer to Tex-121-E, Figure 1, for the recommended amounts of lime to use.
-

14. ARCHIVED VERSIONS

- 14.1 Archived versions are available.

Test Procedure for

CEMENT TREATED MATERIALS



TxDOT Designation: Tex-120-E

Effective Date: April 2022

1. SCOPE

- 1.1 This test method consists of two parts for the laboratory compaction of cement treated materials. Cement treated materials may include subgrade (soils), reclaimed roadway (existing materials), existing materials blended with flexible base, or flexible base only.
- 1.2 Part I is used to determine the optimum moisture content and maximum dry density (M-D) curve in accordance with [Tex-113-E](#) for cement treated materials prepared in the laboratory or sampled from the roadway after mixing. This part may also be used to verify a M-D curve with material sampled from the roadway after mixing.
- 1.2.1 Specimens are compacted using an automatic tamper (compaction) device equipped with a Soil Compactor Analyzer (SCA). All specimens are 6 in. in diameter and 8 ± 0.250 in. in height.
- 1.3 Part II is a mixture design procedure used to determine a target cement content from materials prepared in the laboratory based on the unconfined compressive strength (UCS). This part may also be used to verify the UCS of material sampled from the roadway after mixing.
- 1.3.1 The target cement content is determined from the UCS of compacted specimens after seven days of curing in an environment with a minimum humidity of 95%. The humidity may be measured using a handheld hygrometer.
- 1.3.2 Part II includes an optional moisture conditioning procedure that includes submerging compacted specimens completely in water for 24 hr. after seven days of curing.
-

2. APPARATUS

- 2.1 As outlined in test methods:
- [Tex-100-E](#);
 - [Tex-101-E](#);
 - [Tex-113-E](#);
 - [Tex-117-E](#); and
 - [Tex-400-A](#).
- 2.2 Container, adequate height and volume to completely submerge compacted specimens.
- 2.3 Handheld hygrometer.

2.4 Load cell, minimum 10K (for use with automated load frame).

3. REPORTING

3.1 Report all data and pertinent information pertinent using SiteManager form '[Tx120-21.xlsm](#)'.

3.2 This form is available from the Materials & Tests Division/Soils & Aggregates Section and online at the following link <https://www.txdot.gov/inside-txdot/forms-publications/consultants-contractors/forms/site-manager.html>.

4. MATERIAL SAMPLING AND PREPARATION

4.1 *This test procedure does not claim to address the safety concerns associated with its use. It is the responsibility of the user of this test procedure to establish the appropriate safety, health, and environmental practices and determine the applicability of regulatory limitations before use.*

4.2 Obtain a minimum of 1 gal. of cement in a sealed container from a fresh supply of an approved source from the Department's Material Producer List unless otherwise directed.

4.3 When testing materials for Part I, sample a minimum of 100 lb. in accordance with [Tex-100-E](#) for soils or [Tex-400-A](#) for flexible base and prepare in accordance with [Tex-101-E](#), Part II.

4.4 When testing materials for Part II, sample a minimum of 300 lb. in accordance with [Tex-100-E](#) for soils or [Tex-400-A](#) for flexible base and prepare in accordance with [Tex-101-E](#), Part II.

4.5 When reclaimed asphalt pavement (RAP) is included and greater than 1-3/4 in., resize the RAP to pass the 1-3/4 in. sieve.

Note 1 Heating the RAP to a maximum temperature of 140°F can assist in resizing the RAP.

4.6 When testing material from the roadway after reclamation and mixing, sample the treated material before the start of compaction.

4.6.1 Screen the cement treated material using a 7/8 in. sieve and a 1/4 in. sieve at the field moisture content, without drying.

4.6.2 Separate the material retained on the sieve from the material passing the sieve.

4.6.3 Cover the materials to retain field moisture.

PART I—MOISTURE-DENSITY CURVE

5. PROCEDURE

5.1 *This test procedure does not claim to address the safety concerns associated with its use. It is the responsibility of the user of this test procedure to establish the appropriate safety, health, and environmental practices and determine the applicability of regulatory limitations before use.*

5.2 Select a percentage of cement.

- 5.3 Determine the optimum moisture content and maximum dry density (M-D) curve for the material prepared from Article 4., "Material Sampling and Preparation," in accordance with the applicable Sections of [Tex-113-E](#).
- 5.3.1 Prior to compaction of [Tex-113-E](#), add the cement uniformly to ensure even distribution of the cement throughout the sample. The amount of cement added is a percentage based on the dry mass of the material to be treated.
- 5.4 *Using Roadway Mixed and Treated Material.*
- 5.4.1 Recombine the material from Article 4., "Material Sampling and Preparation," to produce samples for laboratory compaction.
- 5.4.2 Determine the M-D curve for this material in accordance with the applicable Sections of [Tex-113-E](#). Alternatively, compact samples to only verify a M-D curve that was produced from laboratory prepared materials in Section 5.3.
- 5.4.2.1 Estimate the field moisture content. Place material in a pan and weigh to the nearest 0.001 lb.
- 5.4.2.2 Adjust the moisture content of material by adding or removing moisture as needed. When removing moisture, do not oven dry the material. Stir frequently and as needed to achieve the necessary mass of material.
- 5.4.2.3 Determine the mass of material needed to achieve the desired moisture content.
- 5.4.2.4 Weigh material to the nearest 0.001 lb.
-

6. TEST REPORT
- 6.1 Cement Content, 0.1%;
- 6.2 Optimum Moisture Content, 0.1%; and
- 6.3 Maximum Dry Density, 0.1 pcf.
-

PART II—MIXTURE DESIGN TO DETERMINE THE TARGET CEMENT CONENT

7. PROCEDURE
- 7.1 *This test procedure does not claim to address the safety concerns associated with its use. It is the responsibility of the user of this test procedure to establish the appropriate safety, health, and environmental practices and determine the applicability of regulatory limitations before use.*
- 7.2 Determine the optimum moisture content and maximum dry density (M-D) curve using 5% cement for the material prepared from Article 4., "Material Sampling and Preparation," in accordance with the applicable Sections of [Tex-113-E](#).
- 7.2.1 Before compaction of [Tex-113-E](#), add the cement uniformly to ensure even distribution of the cement throughout the sample. The amount of cement added is a percentage based on the dry mass of the material to be treated.

- 7.3 Recombine the material prepared from Article 4., **“Material Sampling and Preparation,”** and mold three samples at 3, 5, and 7% cement in accordance with the applicable Sections of [Tex-113-E](#) to determine the unconfined compressive strength (UCS) at each percentage. Samples may be molded at fewer, more, or different percentages of cement as deemed necessary.
- 7.3.1 Calculate the moisture content for each cement content using equation from Section 8.1 of this test procedure.
- 7.3.2 Before compaction of [Tex-113-E](#), add the cement uniformly to ensure even distribution of the cement throughout the sample. The amount of cement added is a percentage based on the dry mass of the material to be treated.
- 7.3.3 Place a card on each specimen labeling the laboratory identification number and the percent of cement.
- 7.3.4 Proceed to Section 7.5 for curing the specimens.
- 7.4 *Using Roadway Mixed and Treated Material to Verify UCS.*
- 7.4.1 Recombine the material from Article 4., **“Material Sampling and Preparation,”** and mold three samples in accordance with the applicable Sections of [Tex-113-E](#).
- 7.4.1.1 Estimate the field moisture content. Place material in a pan and weigh to the nearest 0.001 lb.
- 7.4.1.2 Adjust the moisture content of material by adding or removing moisture as needed. When removing moisture, do not oven dry the material. Stir frequently and as needed to achieve the necessary mass of material.
- 7.4.1.3 Determine the mass of material needed to achieve the desired moisture content.
- 7.4.1.4 Weigh material to the nearest 0.001 lb.
- 7.5 *Curing.*
- 7.5.1 Store the compacted specimens the same day as molded with the top and bottom porous stones in an environment with a minimum humidity of 95% for seven days. Do not use a triaxial cell.
- 7.5.2 When the humidity is unknown, use a handheld hygrometer to measure the humidity to ensure it is a minimum of 95%.
- 7.5.3 When necessary, place a pan on top of the top porous stone to protect the specimen from any dripping water.
- 7.6 After seven days of curing, remove the test specimens from the environmental room and use a cloth to remove any free water on the surface of the specimens.
- 7.7 Weigh the specimens to the nearest 0.001 lb. and measure the sample height with the micrometer dial assembly to the nearest 0.001 in.
- 7.8 Measure the UCS in accordance with the applicable Sections of [Tex-117-E](#), Part II.
- 7.9 Determine the target cement content using the template from Article 3., **“Reporting,”** with the UCS test results from Section 7.8.
- 7.10 *Optional Moisture Conditioning by 24-hr. Water Submersion.*

- 7.10.1 Use the M-D curve with the calculated moisture content from Sections 7.2, 7.3, or 7.4 from this procedure.
- 7.10.2 Recombine the material prepared from Article 4., **Material Sampling and Preparation,** and mold three samples in accordance with the applicable Sections of Tex-113-E.
- 7.10.2.1 Prior to compaction of Tex-113-E, add the cement uniformly to ensure even distribution of the cement throughout the sample. The amount of cement added is a percentage based on the dry mass of the material to be treated.
- 7.10.3 Cure the compacted specimens in accordance with Section 7.5.
- 7.10.4 Place the specimens with the bottom porous stone only, into the container identified in Section 2.2.
- 7.10.5 Fill the container to approximately 1/2 to 1 in. above the top of the specimens with tap water in a manner that does not disturb and contact the specimens.
- 7.10.6 Soak each specimen in the container for 24 hr. ± 1 hr.
- 7.10.7 Remove each specimen from the container and use an absorptive cloth or paper towel to remove free water on the surface of the specimen.
- 7.10.8 Measure the UCS in accordance with the applicable Sections of Tex-117-E, Part II.
-

8. CALCULATIONS

- 8.1 Use the following equation to determine the percent moisture content at different cement percentages.

$$\% \text{ Moisture Content} = \% \text{ Optimum Moisture} + (0.25 \times \% \text{ Cement Difference})$$

Where:

$\% \text{ Moisture Content}$ = Moisture content of samples prepared for laboratory compaction;

$\% \text{ Optimum Moisture}$ = Optimum moisture content from the Moisture-Density curve; and

$\% \text{ Cement Difference}$ = Difference in cement content between the cement content used for the Moisture-Density curve and the chosen molding cement content.

9. TEST REPORT

- 9.1 Target Cement Content, 0.1%;
- 9.2 Optimum Moisture Content, 0.1%;
- 9.3 Maximum Dry Density, 0.1 pcf; and
- 9.4 Unconfined Compressive Strength, nearest whole psi.

Test Procedure for

LIME TREATED MATERIALS

TxDOT Designation: Tex-121-E

Effective Date: **May 2022**

-
1. SCOPE
 - 1.1 This test method consists of three parts for the laboratory compaction of lime treated materials. Lime treated materials may include subgrade (soils), reclaimed roadway (existing materials), existing materials blended with flexible base, or flexible base only.
 - 1.2 Part I is used to determine the optimum moisture content and maximum dry density (M-D) curve in accordance with [Tex-113-E](#) for lime treated materials prepared in the laboratory or sampled from the roadway after mixing. This part may also be used to verify a M-D curve with material sampled from the roadway after mixing.
 - 1.2.1 Specimens are compacted using an automatic tamper (compaction) device equipped with a Soil Compactor Analyzer (SCA). All specimens are 6 in. in diameter and 8 ± 0.250 in. in height.
 - 1.3 Part II is a mixture design procedure used to determine a target lime content from materials prepared in the laboratory based on the unconfined compressive strength (UCS). This part may also be used to verify the UCS of material sampled from the roadway after mixing.
 - 1.3.1 The target lime content is determined from the minimum percentage of lime to achieve a pH of 12.4 and UCS of compacted specimens after seven days of curing and ten days of capillary rise.
 - 1.4 Part III determines the minimum percent lime needed for a lime treated mixture to achieve a pH of 12.4 in conjunction with [Tex-128-E](#). Cation exchange occurs at this pH where the soil particle structure will achieve improved workability and decrease in swell and plasticity.

-
2. APPARATUS
 - 2.1 As outlined in test methods:
 - [Tex-100-E](#);
 - [Tex-101-E](#);
 - [Tex-113-E](#);
 - [Tex-117-E](#);
 - [Tex-128-E](#); and
 - [Tex-400-A](#).

2.2 Load cell, minimum 10K (for use with automated load frame).

3. REPORTING

3.1 Report all data and pertinent information pertinent using SiteManager form '[Tx120-21.xlsm](#)'.

3.2 This form is available from the Materials & Tests Division/Soils & Aggregates Section and online at the following link <https://www.txdot.gov/inside-txdot/forms-publications/consultants-contractors/forms/site-manager.html>.

4. MATERIAL SAMPLING AND PREPARATION

4.1 *This test procedure does not claim to address the safety concerns associated with its use. It is the responsibility of the user of this test procedure to establish the appropriate safety, health, and environmental practices and determine the applicability of regulatory limitations before use.*

4.2 Obtain a minimum of 1 gal. of hydrated lime in a sealed container from a fresh supply of an approved source from the Department's Material Producer List unless otherwise directed by the lab or project Engineer.

4.3 When testing materials for Part I, sample a minimum of 100 lb. in accordance with [Tex-100-E](#) for soils or [Tex-400-A](#) for flexible base and prepare in accordance with [Tex-101-E](#), Part II.

4.4 When testing materials for Part II, sample a minimum of 300 lb. in accordance with [Tex-100-E](#) for soils or [Tex-400-A](#) for flexible base and prepare in accordance with [Tex-101-E](#), Part II.

4.5 When reclaimed asphalt pavement (RAP) is greater than 1-3/4 in., resize the RAP to pass the 1-3/4 in. sieve.

Note 1 Heating the RAP to a maximum temperature of 140°F can assist in resizing the RAP.

4.6 When testing material from the roadway after reclamation and mixing, sample a minimum of 100 lb. of the treated material before the start of compaction.

4.6.1 Screen the lime treated material using a 7/8 in. sieve and a 1/4 in. sieve at the field moisture content, without drying.

4.6.2 Separate the material retained on the sieve from the material passing the sieve.

4.6.3 Cover the materials to retain field moisture.

PART I—MOISTURE-DENSITY CURVE

5. PROCEDURE

5.1 *This test procedure does not claim to address the safety concerns associated with its use. It is the responsibility of the user of this test procedure to establish the appropriate safety, health, and environmental practices and determine the applicability of regulatory limitations before use.*

- 5.2 Select a percentage of lime.
- 5.3 Determine the optimum moisture content and maximum dry density (M-D) curve for the material prepared from Section 4 in accordance with the applicable Sections of [Tex-113-E](#).
- 5.3.1 Before compaction of [Tex-113-E](#), add the lime uniformly to ensure even distribution of the lime throughout the sample. The amount of lime added is a percentage based on the dry weight of the material to be treated.
- 5.4 *Using Roadway Mixed and Treated Material.*
- 5.4.1 Recombine the material from Section 4 to produce samples for laboratory compaction.
- 5.4.2 Determine the M-D curve for this material in accordance with the applicable Sections of [Tex-113-E](#). Alternatively, compact samples to only verify a M-D curve that was produced from laboratory prepared materials in Section 5.3.
- 5.4.2.1 Estimate the field moisture content. Place material in a pan and weigh to the nearest 0.001 lb.
- 5.4.2.2 Adjust the moisture content of material by adding or removing moisture as needed. When removing moisture, do not oven dry the material. Stir frequently and as needed to achieve the necessary weight of material.
- 5.4.2.3 Determine the mass of material needed to achieve the desired moisture content.
- 5.4.2.4 Weigh material to the nearest 0.001 lb.

6. TEST REPORT

- 6.1 Lime Content, 0.1%;
- 6.2 Optimum Moisture Content, 0.1%; and
- 6.3 Maximum Dry Density, 0.1 pcf.

PART II—MIXTURE DESIGN TO DETERMINE THE TARGET LIME CONTENT

7. PROCEDURE

- 7.1 *This test procedure does not claim to address the safety concerns associated with its use. It is the responsibility of the user of this test procedure to establish the appropriate safety, health, and environmental practices and determine the applicability of regulatory limitations before use.*
- 7.2 Determine the lime content to achieve a pH of 12.4 or higher in accordance with Part III.

- 7.3 Determine the optimum moisture content and maximum dry density (M-D curve) at this lime content for the material prepared from Section 4 in accordance with the applicable Sections of [Tex-113-E](#). A higher lime content may be used.
- 7.3.1 Before compaction of [Tex-113-E](#), add the lime uniformly to ensure even distribution of the lime throughout the sample. The amount of lime added is a percentage based on the dry weight of the material to be treated.
- 7.4 Recombine the material prepared from Section 4 and mold three samples using the M-D curve from Section 7.3.
- 7.5 Place a card on each specimen labeling the laboratory identification number and the percent of lime.
- 7.6 Proceed to Section 7.8 for curing the specimens.
- 7.7 *Using Roadway Mixed and Treated Material to Verify UCS:*
- 7.7.1 Recombine the material from Section 4.6 and mold three samples in accordance with the applicable Sections of [Tex-113-E](#).
- 7.7.2 Estimate the field moisture content. Place material in a pan and weigh to the nearest 0.001 lb.
- 7.7.3 When necessary, adjust the moisture content of material by adding or removing moisture as needed. When removing moisture, do not oven dry the material. Stir frequently and as needed to achieve the necessary weight of material.
- 7.7.4 Determine the mass of material needed to achieve the desired moisture content.
- 7.7.5 Weigh material to the nearest 0.001 lb.
- 7.8 *Curing*
- 7.8.1 Place the compacted specimens in triaxial cells.
- 7.8.2 Enclose the specimens with top and bottom porous stones and store on a countertop for seven days at room temperature.
- 7.9 After seven days of curing, remove the specimens from the triaxial cells.
- 7.9.1 Remove the top porous stone, and place them in an oven with the bottom porous stone only at a maximum temperature of 140°F until 1/3 to 1/2 of the molding moisture has been removed.
- 7.9.1.1 Measure the moisture content from weighing a sample before and after drying periods of time, such as hourly or as deemed necessary to achieve the 1/3 to 1/2 molding moisture. Allow the specimens to cool to room temperature.
- 7.10 Weigh the specimens to the nearest 0.001 lb. and measure the sample height with the micrometer dial assembly to the nearest 0.001 in.
- 7.11 Enclose the specimens in triaxial cells, with top and bottom porous stones.

- 7.12 Subject the specimens to capillary rise for ten days in accordance with [Tex-117-E](#), Sections 5.8-5.13, Figure 1, and Table 1.
- 7.13 Measure the unconfined compressive strength (UCS) in accordance with the applicable Sections of [Tex-117-E](#), Part II.
- 7.14 When testing lime treated soil, if the UCS is less than 50 psi or less than the minimum UCS as shown on plans, a new mixture design is required. Proceed to Section 7.3 and add a minimum of one additional percent of lime to the soil.
- 7.15 When testing lime treated soil blended with existing materials, or lime treated flexible base, or lime treated flexible base blended with existing materials, if the UCS is less than 150 psi or less than the minimum UCS as shown on plans, a new mixture design is required. Proceed to Section 7.3 and add a minimum of one additional percent of lime to the material.

8. TEST REPORT

- 8.1 Target Lime Content, 0.1%.
- 8.2 Optimum Moisture Content, 0.1%;
- 8.3 Maximum Dry Density, 0.1 pcf; and
- 8.4 Unconfined Compressive Strength, nearest whole psi.

PART III—PH SERIES

9. PROCEDURE

- 9.1 *This test procedure does not claim to address the safety concerns associated with its use. It is the responsibility of the user of this test procedure to establish the appropriate safety, health, and environmental practices and determine the applicability of regulatory limitations before use.*
- 9.2 Prepare the sample in accordance with [Tex-128-E](#).
- 9.3 Weigh 30 ± 0.01 g of the sample and place it in a clean container. Repeat five additional times to weigh up a total of six test samples in six different containers.
- 9.4 Weigh 0.6 ± 0.01 g of lime which is 2% of the dry sample weight of 30 g and combine it with one of the samples from Section 9.2.
- 9.5 Repeat this for lime contents of 4, 6, 8, and 10% by adding 1.2 ± 0.01 , 1.8 ± 0.01 , 2.4 ± 0.01 , and 3.0 ± 0.01 g of lime, respectively, into a sample from Section 9.2. One sample from Section 9.2 will not be combined with any lime and tested as is at 0% lime.
- 9.6 Measure the pH of each sample from Section 9.3 and 9.4 in accordance with [Tex-128-E](#).

- 9.6.1 When the pH readings are 12.4 or higher, the sample with the lowest percentage of lime is the percent required to treat the material.
- 9.6.2 When the pH readings do not go above 12.3 and two or more samples give this reading, the sample with the lowest percentage of lime is the percent required to treat the material.
- 9.6.3 When the highest pH reading is 12.3 and only the sample with the highest percentage of lime achieves this, additional testing is required using higher percentages of lime.
-

10. TEST REPORT

- 10.1 Lime Treated Sample pH, 0.1%.

Test Procedure for**PH TESTING OF SOILS AND RETAINING WALL
BACKFILL**TxDOT Designation: **Tex-128-E****Effective Date: July 2024**

1. SCOPE

- 1.1 This method describes the procedure for determining a pH value of material in a water solution using a pH meter. Materials tested include lime treated material, retaining wall backfill, and topsoil.
 - 1.2 Lime treated material is tested to determine the percent of lime to achieve a pH of 12.4 to optimize stabilization for long term strength gain. Retaining wall backfill is tested for the potential of corrosion of galvanized metallic earth reinforcements such that the pH is between 5.5 –10. Topsoil is tested for its suitability for plant growth that is between 5.5 –8.5.
 - 1.3 *This test procedure does not claim to address the safety concerns associated with its use. It is the responsibility of the user of this test procedure to establish the appropriate safety, health, and environmental practices and determine the applicability of regulatory limitations before use.*
-

2. APPARATUS

- 2.1 Balance, Class G1 in accordance with [Tex-901-K](#), minimum capacity 1,500 g.
 - 2.2 Buffer solutions, pH 4.0, 7.0, and 10.0.
 - 2.3 Glass beaker, 250 mL (8.5 fl. oz.)
 - 2.4 Glass stirring rod.
 - 2.5 pH meter, with glass electrode, pH range 0–14 ± 0.1.
 - 2.6 Stirring device, mechanical or magnetic.
 - 2.7 Thermometer, 32–212°F.
-

3. MATERIALS

- 3.1 Distilled or deionized water.

4. PREPARING SAMPLES

- 4.1 Sample a minimum of 50 lbs. of embankment (soils) material, non-select backfill, or topsoil in accordance with [Tex-100-E](#).
- 4.2 Sample a minimum of 50 lbs. of select backfill in accordance with [Tex-400-A](#).
- 4.3 Prepare the sample in accordance with [Tex-101-E](#), Part I to obtain material passing the No. 40 sieve for testing.
-

5. STANDARDIZATION

- 5.1 Standardize the pH meter using standard buffer solution of pH 4.0, 7.0, and 10.0 according to the manufacturer's recommendations.
-

6. PROCEDURE

- 6.1 Place 30 ± 0.1 g of material into a glass beaker.
- 6.2 Add 150 mL (5 fl. oz.) of distilled water into the glass beaker.
- 6.3 Stir with a glass stirring rod or device for approximately 1 min. to disperse the soil and obtain a soil slurry.
- 6.4 Allow the sample to stand for a minimum of 1 hr., stirring every 15 min. to disperse the soil and to allow the pH of the slurry to stabilize.
- 6.4.1 Stir the slurry for approximately 1 min.
- 6.5 Measure and record the temperature of the mixture and adjust the pH meter to that temperature.
- 6.5.1 Adjust the temperature before testing.
- 6.5.2 Follow the manufacturer's recommendations when using a pH meter with an automatic temperature control.
- 6.6 Rinse the electrode with distilled water. Do not rinse the electrode over the beaker and do not wipe the electrode as this could damage it.
- 6.7 Immediately before immersing the electrode into mixture, stir for approximately 1 min.
- 6.8 Place the electrode into the solution and leave it immersed until the reading has stabilized.
- 6.8.1 Do not place the electrode into the soil, and do not hit the bottom or side of the glass beaker as this may damage the electrode.
- 6.8.2 Meters with an auto-read system will automatically signal when stabilized.
- 6.9 Record the pH to the nearest 0.1 pH unit.
- 6.10 Remove the electrode and rinse with distilled water. Refer to the manufacturer's recommendations for proper handling and storage.
-

7. REPORT

7.1 Report the pH to the nearest 0.1.

8. ARCHIVED VERSIONS

8.1 Archived versions are available.

Item 247

Flexible Base



1. DESCRIPTION

Construct a foundation course composed of flexible base.

2. MATERIALS

Furnish uncontaminated materials of uniform quality that meet the requirements of the plans and specifications. Notify the Engineer of the proposed material sources and of changes to material sources. The Engineer may sample and test project materials at any time before compaction throughout the duration of the project to assure specification compliance. Use Tex-100-E material definitions.

- 2.1. **Aggregate.** Furnish aggregate of the type and grade shown on the plans and meeting the requirements of Table 1. Each source must meet Table 1 requirements for liquid limit, plasticity index, and wet ball mill for the grade specified. Do not use additives, such as but not limited to lime, cement, or fly ash to modify aggregates to meet the requirements of Table 1 unless shown on the plans.

Table 1
Material Requirements

Property	Test Method	Grade 1-2	Grade 3	Grade 4 ²	Grade 5
Sampling	Tex-400-A				
Master gradation sieve size (cumulative % retained)	Tex-110-E			As shown on the plans	
2-1/2"		0	0		0
1-3/4"		0-10	0-10		0-5
7/8"		10-35	-		10-35
3/8"		30-65	-		35-65
#4		45-75	45-75		45-75
#40	65-90	50-85	70-90		
Liquid Limit, % Max	Tex-104-E	40	40	As shown on the plans	35
Plasticity Index, Max ¹	Tex-106-E	10	12	As shown on the plans	10
Plasticity index, Min ¹		As shown on the plans	As shown on the plans	As shown on the plans	As shown on the plans
Wet ball mill, % Max	Tex-116-E	40	-	As shown on the plans	40
Wet ball mill, % Max increase passing the #40 sieve		20	-	As shown on the plans	20
Min compressive strength, psi	Tex-117-E			As shown on the plans	
lateral pressure 0 psi		35	-		-
lateral pressure 3 psi		-	-		90
lateral pressure 15 psi		175	-		175

- Determine plastic index in accordance with Tex-107-E (linear shrinkage) when liquid limit is unattainable as defined in Tex-104-E.
- Grade 4 may be further designated as Grade 4A, Grade 4B, etc.

- 2.1.1. **Material Tolerances.** The Engineer may accept material if no more than 1 of the 5 most recent gradation tests has an individual sieve outside the specified limits of the gradation.

When target grading is required by the plans, no single failing test may exceed the master grading by more than 5 percentage points on sieves No. 4 and larger or 3 percentage points on sieves smaller than No. 4.

The Engineer may accept material if no more than 1 of the 5 most recent plasticity index tests is outside the specified limit. No single failing test may exceed the allowable limit by more than 2 points.

- 2.1.2. **Material Types.** Do not use fillers or binders unless approved. Furnish the type specified on the plans in accordance with the following:
- 2.1.2.1. **Type A.** Crushed stone produced and graded from oversize quarried aggregate that originates from a single, naturally occurring source. Do not use gravel or multiple sources.
- 2.1.2.2. **Type B.** Crushed or uncrushed gravel. Blending of 2 or more sources is allowed.
- 2.1.2.3. **Type C.** Crushed gravel with a minimum of 60% of the particles retained on a No. 4 sieve with 2 or more crushed faces as determined by Tex-460-A, Part I. Blending of 2 or more sources is allowed.
- 2.1.2.4. **Type D.** Type A material or crushed concrete. Crushed concrete containing gravel will be considered Type D material. Crushed concrete must meet the requirements in Section 247.2.1.3.2., "Recycled Material (Including Crushed Concrete) Requirements," and be managed in a way to provide for uniform quality. The Engineer may require separate dedicated stockpiles in order to verify compliance.
- 2.1.2.5. **Type E.** Caliche, iron ore or as otherwise shown on the plans.
- 2.1.3. **Recycled Material.** Reclaimed asphalt pavement (RAP) and other recycled materials may be used when shown on the plans. Request approval to blend 2 or more sources of recycled materials.
- 2.1.3.1. **Limits on Percentage.** Do not exceed 20% RAP by weight, when RAP is allowed, unless otherwise shown on the plans. The percentage limitations for other recycled materials will be as shown on the plans.
- 2.1.3.2. **Recycled Material (Including Crushed Concrete) Requirements.**
- 2.1.3.2.1. **Contractor-Furnished Recycled Materials.** Provide recycled materials, other than RAP, that have a maximum sulfate content of 3,000 ppm when tested in accordance with Tex-145-E. When the Contractor furnishes the recycled materials, including crushed concrete, the final product will be subject to the requirements of Table 1 for the grade specified. Certify compliance with DMS-11000, "Evaluating and Using Nonhazardous Recyclable Materials Guidelines," for Contractor furnished recycled materials. In addition, recycled materials must be free from reinforcing steel and other objectionable material and have at most 1.5% deleterious material when tested in accordance with Tex-413-A. For RAP, do not exceed a maximum percent loss from decantation of 5.0% when tested in accordance with Tex-406-A. Test RAP without removing the asphalt.
- 2.1.3.2.2. **Department-Furnished Required Recycled Materials.** When the Department furnishes and requires the use of recycled materials, unless otherwise shown on the plans:
- Department-required recycled material will not be subject to the requirements in Table 1,
 - Contractor-furnished materials are subject to the requirements in Table 1 and this Item,
 - the final product, blended, will be subject to the requirements in Table 1, and
 - for final product, unblended (100% Department-furnished required recycled material), the liquid limit, plasticity index, wet ball mill, and compressive strength is waived.
- Crush Department-furnished RAP so that 100% passes the 2 in. sieve. The Contractor is responsible for uniformly blending to meet the percentage required.
- 2.1.3.2.3. **Department-Furnished and Allowed Recycled Materials.** When the Department furnishes and allows the use of recycled materials or allows the Contractor to furnish recycled materials, the final blended product is subject to the requirements of Table 1 and the plans.

- 2.1.3.3. **Recycled Material Sources.** Department-owned recycled material is available to the Contractor only when shown on the plans. Return unused Department-owned recycled materials to the Department stockpile location designated by the Engineer unless otherwise shown on the plans.

The use of Contractor-owned recycled materials is allowed when shown on the plans. Contractor-owned surplus recycled materials remain the property of the Contractor. Remove Contractor-owned recycled materials from the project and dispose of them in accordance with federal, state, and local regulations before project acceptance. Do not intermingle Contractor-owned recycled material with Department-owned recycled material unless approved.

- 2.2. **Water.** Furnish water free of industrial wastes and other objectionable matter.
- 2.3. **Material Sources.** Expose the vertical faces of all strata of material proposed for use when non-commercial sources are used. Secure and process the material by successive vertical cuts extending through all exposed strata, when directed.

3. EQUIPMENT

Provide machinery, tools, and equipment necessary for proper execution of the work.

- 3.1. Provide rollers in accordance with Item 210, "Rolling." Provide proof rollers in accordance with Item 216, "Proof Rolling," when required.
- 3.2. When ride quality measurement is required, provide a high speed or lightweight inertial profiler certified at the Texas A&M Transportation Institute. Provide equipment certification documentation. Display a current decal on the equipment indicating the certification expiration date.

4. CONSTRUCTION

Construct each layer uniformly, free of loose or segregated areas, and with the required density and moisture content. Provide a smooth surface that conforms to the typical sections, lines, and grades shown on the plans or as directed.

Stockpile base material temporarily at an approved location before delivery to the roadway. Build stockpiles in layers no greater than 2 ft. thick. Stockpiles must have a total height between 10 and 16 ft. unless otherwise approved. After construction and acceptance of the stockpile, loading from the stockpile for delivery is allowed. Load by making successive vertical cuts through the entire depth of the stockpile.

Do not add or remove material from temporary stockpiles that require sampling and testing before delivery unless otherwise approved. Charges for additional sampling and testing required as a result of adding or removing material will be deducted from the Contractor's estimates.

Haul approved flexible base in clean trucks. Deliver the required quantity to each 100-ft. station or designated stockpile site as shown on the plans. Prepare stockpile sites as directed. When delivery is to the 100-ft. station, manipulate in accordance with the applicable Items.

- 4.1. **Preparation of Subgrade or Existing Base.** Remove or scarify existing asphalt concrete pavement in accordance with Item 105, "Removing Treated and Untreated Base and Asphalt Pavement," when shown on the plans or as directed. Shape the subgrade or existing base to conform to the typical sections shown on the plans or as directed.

When new base is required to be mixed with existing base, deliver, place, and spread the new flexible base in the required amount per station. Manipulate and thoroughly mix the new base with existing material to provide a uniform mixture to the specified depth before shaping.

Proof roll the roadbed in accordance with Item 216, "Proof Rolling," before pulverizing or scarifying when shown on the plans or directed. Correct soft spots as directed.

- 4.2. **Placing.** Spread and shape flexible base into a uniform layer with an approved spreader the same day as delivered unless otherwise approved. Construct layers to the thickness shown on the plans. Maintain the shape of the course. Control dust by sprinkling, as directed. Correct or replace segregated areas as directed, at no additional expense to the Department.

Place successive base courses and finish courses using the same construction methods required for the first course.

- 4.3. **Compaction.** Compact using density control unless otherwise shown on the plans. Multiple lifts are permitted when shown on the plans or approved. Bring each layer to the moisture content directed. When necessary, sprinkle the material in accordance with Item 204, "Sprinkling."

Begin rolling longitudinally at the sides and proceed towards the center, overlapping on successive trips by at least 1/2 the width of the roller unit. Begin rolling at the low side and progress toward the high side on superelevated curves. Offset alternate trips of the roller. Operate rollers at a speed between 2 and 6 mph as directed.

Rework, recompact, and refinish material that fails to meet or that loses required moisture, density, stability, or finish requirements before the next course is placed or the project is accepted. Continue work until specification requirements are met. Perform the work at no additional expense to the Department.

Before final acceptance, the Engineer will select the locations of tests and measure the flexible base depth in accordance with Tex-140-E. Correct areas deficient by more than 1/2 in. in thickness by scarifying, adding material as required, reshaping, recompacting, and refinishing at the Contractor's expense.

- 4.3.1. **Ordinary Compaction.** Roll with approved compaction equipment as directed. Correct irregularities, depressions, and weak spots immediately by scarifying the areas affected, adding or removing approved material as required, reshaping, and recompacting.

- 4.3.2. **Density Control.** Compact to at least 100% of the maximum dry density determined by Tex-113-E, unless otherwise shown on the plans. Maintain moisture during compaction within ± 2 percentage points of the optimum moisture content as determined by Tex-113-E. Measure the moisture content of the material in accordance with Tex-115-E or Tex-103-E during compaction daily and report the results the same day to the Engineer, unless otherwise shown on the plans or directed. Do not achieve density by drying the material after compaction.

The Engineer will determine roadway density and moisture content of completed sections in accordance with Tex-115-E. The Engineer may accept the section if no more than 1 of the 5 most recent density tests is below the specified density and the failing test is no more than 3 pcf below the specified density.

- 4.4. **Finishing.** After completing compaction, clip, skin, or tight-blade the surface with a maintainer or subgrade trimmer to a depth of approximately 1/4 in. Remove loosened material and dispose of it at an approved location. Seal the clipped surface immediately by rolling with a pneumatic tire roller until a smooth surface is attained. Add small increments of water as needed during rolling. Shape and maintain the course and surface in conformity with the typical sections, lines, and grades as shown on the plans or as directed.

Correct grade deviations greater than 1/4 in. in 16 feet measured longitudinally or greater than 1/4 in. over the entire width of the cross-section in areas where surfacing is to be placed. Correct by loosening and adding, or removing material. Reshape and re-compact in accordance with Section 247.4.3., "Compaction."

- 4.5. **Curing.** Cure the finished section until the moisture content is at least 2 percentage points below optimum or as directed before applying the next successive course or prime coat.

- 4.6. **Ride Quality.** This section applies to the final travel lanes that receive a 1 or 2 course surface treatment for the final surface, unless otherwise shown on the plans. Measure ride quality of the base course after placement of the prime coat and before placement of the surface treatment, unless otherwise approved. Use a certified profiler operator from the Department's MPL. When requested, furnish the Engineer documentation for the person certified to operate the profiler.

Provide all profile measurements to the Engineer in electronic data files within 3 days after placement of the prime coat using the format specified in Tex-1001-S. The Engineer will use Department software to evaluate longitudinal profiles to determine areas requiring corrective action. Correct 0.1-mi.sections having an average international roughness index (IRI) value greater than 100.0 in. per mile to an IRI value of 100.0 in. per mile or less for each wheel path, unless otherwise shown on the plans.

Re-profile and correct sections that fail to maintain ride quality until placement of the next course, as directed. Correct re-profiled sections until specification requirements are met, as approved. Perform this work at no additional expense to the Department.

5. MEASUREMENT

Flexible base will be measured as follows:

- **Flexible Base (Complete In Place).** The ton, square yard, or any cubic yard method.
- **Flexible Base (Roadway Delivery).** The ton or any cubic yard method.
- **Flexible Base (Stockpile Delivery).** The ton, cubic yard in vehicle, or cubic yard in stockpile.

Measurement by the cubic yard in final position and square yard is a plans quantity measurement. The quantity to be paid for is the quantity shown in the proposal unless modified by Article 9.2., "Plans Quantity Measurement." Additional measurements or calculations will be made if adjustments of quantities are required.

Measurement is further defined for payment as follows.

- 5.1. **Cubic Yard in Vehicle.** By the cubic yard in vehicles of uniform capacity at the point of delivery.
- 5.2. **Cubic Yard in Stockpile.** By the cubic yard in the final stockpile position by the method of average end areas.
- 5.3. **Cubic Yard in Final Position.** By the cubic yard in the completed and accepted final position. The volume of base course is computed in place by the method of average end areas between the original subgrade or existing base surfaces and the lines, grades, and slopes of the accepted base course as shown on the plans.
- 5.4. **Square Yard.** By the square yard of surface area in the completed and accepted final position. The surface area of the base course is based on the width of flexible base as shown on the plans.
- 5.5. **Ton.** By the ton of dry weight in vehicles as delivered. The dry weight is determined by deducting the weight of the moisture in the material at the time of weighing from the gross weight of the material. The Engineer will determine the moisture content in the material in accordance with Tex-103-E from samples taken at the time of weighing.

When material is measured in trucks, the weight of the material will be determined on certified scales, or the Contractor must provide a set of standard platform truck scales at a location approved by the Engineer. Scales must conform to the requirements of Item 520, "Weighing and Measuring Equipment."

6. PAYMENT

The work performed and materials furnished in accordance with this Item and measured as provided under "Measurement" will be paid for at the unit price bid for the types of work shown below. No additional payment

will be made for thickness or width exceeding that shown on the typical section or provided on the plans for cubic yard in the final position or square yard measurement.

Sprinkling and rolling, except proof rolling, will not be paid for directly but will be subsidiary to this Item unless otherwise shown on the plans. When proof rolling is shown on the plans or directed, it will be paid for in accordance with Item 216, "Proof Rolling."

Where subgrade is constructed under this Contract, correction of soft spots in the subgrade will be at the Contractor's expense. Where subgrade is not constructed under this Contract, correction of soft spots in the subgrade will be paid in accordance with pertinent Items or Article 4.4., "Changes in the Work."

- 6.1. **Flexible Base (Complete In Place).** Payment will be made for the type and grade specified. For cubic yard measurement, "In Vehicle," "In Stockpile," or "In Final Position" will be specified. For square yard measurement, a depth will be specified. This price is full compensation for furnishing materials, temporary stockpiling, assistance provided in stockpile sampling and operations to level stockpiles for measurement, loading, hauling, delivery of materials, spreading, blading, mixing, shaping, placing, compacting, reworking, finishing, correcting locations where thickness is deficient, curing, furnishing scales and labor for weighing and measuring, and equipment, labor, tools, and incidentals.
- 6.2. **Flexible Base (Roadway Delivery).** Payment will be made for the type and grade specified. For cubic yard measurement, "In Vehicle," "In Stockpile," or "In Final Position" will be specified. The unit price bid will not include processing at the roadway. This price is full compensation for furnishing materials, temporary stockpiling, assistance provided in stockpile sampling and operations to level stockpiles for measurement, loading, hauling, delivery of materials, furnishing scales and labor for weighing and measuring, and equipment, labor, tools, and incidentals.
- 6.3. **Flexible Base (Stockpile Delivery).** Payment will be made for the type and grade specified. For cubic yard measurement, "In Vehicle" or "In Stockpile" will be specified. The unit price bid will not include processing at the roadway. This price is full compensation for furnishing and disposing of materials, preparing the stockpile area, temporary or permanent stockpiling, assistance provided in stockpile sampling and operations to level stockpiles for measurement, loading, hauling, delivery of materials to the stockpile, furnishing scales and labor for weighing and measuring, and equipment, labor, tools, and incidentals.

Item 260

Lime Treatment (Road-Mixed)



1. DESCRIPTION

Mix and compact lime, water, and subgrade or base (with or without asphaltic concrete pavement) in the roadway.

2. MATERIALS

Furnish uncontaminated materials of uniform quality that meet the requirements of the plans and specifications. Notify the Engineer of the proposed material sources and of changes to material sources. Obtain verification from the Engineer that the specification requirements are met before using the sources. The Engineer may sample and test project materials at any time before compaction. Use Tex-100-E for material definitions.

- 2.1. **Lime.** Furnish lime that meets the requirements of DMS-6350 "Lime and Lime Slurry," and DMS-6330, "Pre-Qualification of Lime Sources." Use hydrated lime, commercial lime slurry, quicklime, or carbide lime slurry as shown on the plans. Do not use quicklime when sulfates are present in quantities greater than 3,000 ppm. When furnishing quicklime, provide it in bulk.
- 2.2. **Subgrade.** The Engineer will determine the sulfate content of the existing subgrade in accordance with Tex-145-E and organic content in accordance with Tex-148-E before lime treatment begins. Suspend operations when material to be treated has a sulfate content greater than 7,000 ppm or an organic content greater than 1.0% and proceed as directed.
- 2.3. **Flexible Base.** Unless otherwise shown on the plans, furnish base material that meets the requirements of Item 247, "Flexible Base," for the type and grade shown on the plans, before the addition of lime.
- 2.4. **Water.** Furnish water free of industrial wastes and other objectionable material.
- 2.5. **Asphalt.** When asphalt or emulsion is permitted for curing purposes, furnish materials that meet the requirements of Item 300, "Asphalts, Oils, and Emulsions," as shown on the plans or as directed.
- 2.6. **Mix Design.** The Engineer will determine the target lime content and optimum moisture content in accordance with Tex-121-E or prior experience with the project materials. The Contractor may propose a mix design developed in accordance with Tex-121-E. The Engineer will use Tex-121-E to verify the Contractor's proposed mix design before acceptance. Reimburse the Department for subsequent mix designs or partial designs necessitated by changes in the material or requests by the Contractor. Limit the amount of recycled asphalt pavement to no more than 50% of the mix unless otherwise shown on the plans or directed.

3. EQUIPMENT

Provide machinery, tools, and equipment necessary for proper execution of the work. Provide rollers in accordance with Item 210, "Rolling." Provide proof rollers in accordance with Item 216, "Proof Rolling," when required.

- 3.1. **Storage Facility.** Store quicklime and dry hydrated lime in closed, weatherproof containers.
- 3.2. **Slurry Equipment.** Use slurry tanks equipped with agitation devices to slurry hydrated lime or quicklime on the project or other approved location. The Engineer may approve other slurring methods.

- 3.3. Provide a pump for agitating the slurry when the distributor truck is not equipped with an agitator. Equip the distributor truck with a sampling device in accordance with Tex-600-J, Part I, when using commercial lime slurry or carbide lime slurry.
- 3.4. **Hydrated Lime Distribution Equipment.** Provide equipment to spread lime evenly across the area to be treated. Provide equipment with a rotary vane feeder to spread lime, when shown on the plans.
- 3.5. **Pulverization Equipment.** Provide pulverization equipment that:
- cuts and pulverizes material uniformly to the proper depth with cutters that plane to a uniform surface over the entire width of the cut,
 - provides a visible indication of the depth of cut at all times, and
 - uniformly mixes the materials.

4. CONSTRUCTION

Construct each layer uniformly, free of loose or segregated areas, and with the required density and moisture content. Provide a smooth surface that conforms to the typical sections, lines, and grades shown on the plans or as directed.

- 4.1. **Preparation of Subgrade or Existing Base for Treatment.** Before treating, remove existing asphalt pavement in accordance with Item 105, "Removing Treated and Untreated Base and Asphalt Pavement," when shown on the plans or as directed. Shape existing material in accordance with applicable bid items to conform to typical sections shown on the plans and as directed.

Unless otherwise approved, proof roll the roadbed in accordance with Item 216, "Proof Rolling," before pulverizing or scarifying existing material. Correct soft spots as directed.

When material is imported from a borrow source, notify the Engineer of the location of the borrow source well in advance to allow time for testing and approval to avoid delay to the project. Stockpile as directed. The Engineer will test the borrow source and determine the sulfate and organic contents. When the borrow source has a sulfate content greater than 3,000 ppm or an organic content greater than 1.0%, proceed as directed.

When new base material is required to be mixed with existing base, deliver, place, and spread the new material in the required amount per station. Manipulate and thoroughly mix new base with existing material to provide a uniform mixture to the specified depth before shaping.

- 4.2. **Pulverization.** Pulverize or scarify existing material after shaping so that 100% passes a 2-1/2 in. sieve. If the material cannot be uniformly processed to the required depth in a single pass, excavate and windrow the material to expose a secondary grade to achieve processing to plan depth.
- 4.3. **Application of Lime.** Uniformly apply lime using dry or slurry placement as shown on the plans or as directed. Add lime at the percentage determined in Section 260.2.6., "Mix Design." Apply lime only on an area where mixing can be completed during the same working day.

Start lime application only when the air temperature is at least 35°F and rising or is at least 40°F. The temperature will be taken in the shade and away from artificial heat. Suspend application when the Engineer determines that weather conditions are unsuitable.

Minimize dust and scattering of lime by wind. Do not apply lime when wind conditions, in the opinion of the Engineer, cause blowing lime to become dangerous to traffic or objectionable to adjacent property owners. When pebble grade quicklime is placed dry, mix the material and lime thoroughly at the time of lime application. Use of quicklime can be dangerous. Inform users of the recommended precautions for handling and storage.

- 4.3.1. **Dry Placement.** Before applying lime, bring the prepared roadway to approximately 2 percentage points above optimum moisture content. When necessary, sprinkle in accordance with Item 204, "Sprinkling." Distribute the required quantity of hydrated lime or pebble grade quicklime with approved equipment. Only hydrated lime may be distributed by bag. Do not use a motor grader to spread hydrated lime.
- 4.3.2. **Slurry Placement.** Provide slurry free of objectionable materials, at or above the minimum dry solids content, and with a uniform consistency that will allow ease of handling and uniform application. Deliver commercial lime slurry or carbide lime slurry to the jobsite, or use hydrated lime or quicklime to prepare lime slurry at the jobsite or other approved location, as specified. When dry quicklime is applied as slurry, use 80% of the amount shown on the plans.
- Distribute slurry uniformly by making successive passes over a measured section of roadway until the specified lime content is reached. Uniformly spread the residue from quicklime slurry over the length of the roadway being processed, unless otherwise directed.
- 4.4. **Mixing.** Begin mixing within 6 hr. of application of lime. Hydrated lime exposed to the open air for 6 hr. or more between application and mixing, or that experiences excessive loss due to washing or blowing, will not be accepted for payment.

Thoroughly mix the material and lime using approved equipment. When treating subgrade, bring the moisture content above the optimum moisture content to insure adequate chemical reaction of the lime and subgrade materials. Allow the mixture to mellow for 1 to 4 days, as directed. When pebble grade quicklime is used, allow the mixture to mellow for 2 to 4 days, as directed. Sprinkle the treated materials during the mixing and mellowing operation, as directed, to achieve adequate hydration and proper moisture content. When the material to be treated has a sulfate content greater than 3,000 ppm but less than or equal to 7,000 ppm, mellow for a minimum of 7 days. Maintain in a continuously moist condition by sprinkling in accordance with Item 204, "Sprinkling." After mellowing, resume mixing until a homogeneous, friable mixture is obtained. After mixing, the Engineer may sample the mixture at roadway moisture and test in accordance with Tex-101-E, Part III, to determine compliance with the gradation requirements in Table 1.

Table 1
Gradation Requirements (Minimum % Passing)

Sieve Size	Base	Subgrade
1-3/4"	100	100
3/4"	85	85
#4	–	60

- 4.5. **Compaction.** Compact the mixture using density control, unless otherwise shown on the plans. Multiple lifts are permitted when shown on the plans or approved. Bring each layer to the moisture content directed. Sprinkle the treated material in accordance with Item 204, "Sprinkling" or aerate the treated material to adjust the moisture content during compaction so that it is no more than 1.0 percentage points below optimum and 2.0 percentage points above optimum as determined by Tex-121-E. Measure the moisture content of the material in accordance with Tex-115-E or Tex-103-E during compaction daily and report the results the same day, unless otherwise shown on the plans or directed.

Begin rolling longitudinally at the sides and proceed toward the center, overlapping on successive trips by at least 1/2 the width of the roller unit. On superelevated curves, begin rolling at the low side and progress toward the high side. Offset alternate trips of the roller. Operate rollers at a speed between 2 and 6 mph as directed.

Before final acceptance, the Engineer will select the locations of tests in each unit and measure the treated depth in accordance with Tex-140-E. Correct areas deficient by more than 1/2 in. in thickness or more than 1/2% in target lime content by adding lime as required, reshaping, recompacting, and refinishing at the Contractor's expense.

Rework, recompact, and refinish material that fails to meet or that loses required moisture, density, stability, or finish before the next course is placed or the project is accepted. Continue work until specification

requirements are met. Rework in accordance with Section 260.4.6., "Reworking a Section." Perform the work at no additional expense to the Department.

- 4.5.1. **Ordinary Compaction.** Roll with approved compaction equipment, as directed. Correct irregularities, depressions, and weak spots immediately by scarifying the areas affected, adding or removing treated material as required, reshaping, and recompacting.
- 4.5.2. **Density Control.** The Engineer will determine roadway density and moisture content of completed sections in accordance with Tex-115-E. The Engineer may accept the section if no more than 1 of the 5 most recent density tests is below the specified density and the failing test is no more than 3 pcf below the specified density.
- 4.5.2.1. **Subgrade.** Compact to at least 95% of the maximum density determined in accordance with Tex-121-E, unless otherwise shown on the plans.
- 4.5.2.2. **Base.** Compact the bottom course to at least 95% of the maximum density determined in accordance with Tex-121-E, unless otherwise shown on the plans. Compact subsequent courses treated under this Item to at least 98% of the maximum density determined in accordance with Tex-121-E, unless otherwise shown on the plans.
- 4.6. **Reworking a Section.** When a section is reworked within 72 hr. after completion of compaction, rework the section to provide the required density. When a section is reworked more than 72 hr. after completion of compaction, add additional lime at 25% of the percentage determined in Section 260.2.6., "Mix Design." Reworking includes loosening, adding material or removing unacceptable material if necessary, mixing as directed, compacting, and finishing. When density control is specified, determine a new maximum density of the reworked material in accordance with Tex-121-E, and compact to at least 95% of this density.
- 4.7. **Finishing.** Immediately after completing compaction of the final course, clip, skin, or tight-blade the surface of the lime-treated material with a maintainer or subgrade trimmer to a depth of approximately 1/4 in. Remove loosened material and dispose of at an approved location. Roll the clipped surface immediately with a pneumatic tire roller until a smooth surface is attained. Add small amounts of water as needed during rolling. Shape and maintain the course and surface in conformity with the typical sections, lines, and grades shown on the plans or as directed.
- Finish grade of constructed subgrade to within 0.1 ft. in the cross-section and 0.1 ft. in 16 ft. measured longitudinally.
- Correct grade deviations of constructed base greater than 1/4 in. in 16 ft. measured longitudinally or greater than 1/4 in. over the entire width of the cross-section in areas where surfacing is to be placed. Remove excess material, reshape, and roll with a pneumatic-tire roller. Correct as directed if material is more than 1/4 in. low. Do not surface patch. The 72-hr. time limit required for completion of placement, compaction, and finishing does not apply to finishing required just before applying the surface course.
- 4.8. **Curing.** Cure for the minimum number of days shown in Table 2 by sprinkling in accordance with Item 204, "Sprinkling," or by applying an asphalt material at a rate of 0.05 to 0.20 gal. per square yard as directed. Maintain moisture during curing. Upon completion of curing, maintain the moisture content in accordance with Section 132.3.5., "Maintenance of Moisture and Reworking," for subgrade and Section 247.4.5., "Curing" for bases before placing subsequent courses. Do not allow equipment on the finished course during curing except as required for sprinkling, unless otherwise approved. Apply seals or additional courses within 14 calendar days of final compaction.

Table 2
Minimum Curing Requirements before Placing Subsequent Courses¹

Untreated Material	Curing (Days)
PI ≤ 35	2
PI > 35	5

1. Subject to the approval of the Engineer. Proof rolling may be required as an indicator of adequate curing.

5. MEASUREMENT

- 5.1. **Lime.** When lime is furnished in trucks, the weight of lime will be determined on certified scales, or the Contractor must provide a set of standard platform truck scales at a location approved by the Engineer. Scales must conform to the requirements of Item 520, "Weighing and Measuring Equipment."

When lime is furnished in bags, indicate the manufacturer's certified weight. Bags varying more than 5% from that weight may be rejected. The average weight of bags in any shipment, as determined by weighing 10 bags taken at random, must be at least the manufacturer's certified weight.

5.1.1. Hydrated Lime.

- 5.1.1.1. **Dry.** Lime will be measured by the ton (dry weight).

- 5.1.1.2. **Slurry.** Lime slurry will be measured by the ton (dry weight) of the hydrated lime used to prepare the slurry at the jobsite.

- 5.1.2. **Commercial Lime Slurry.** Lime slurry will be measured by the ton (dry weight) as calculated from the minimum percent dry solids content of the slurry, multiplied by the weight of the slurry in tons delivered.

5.1.3. Quicklime.

- 5.1.3.1. **Dry.** Lime will be measured by the ton (dry weight) of the quicklime.

- 5.1.3.2. **Slurry.** Lime slurry will be measured by the ton (dry weight) of the quicklime used to prepare the slurry multiplied by a conversion factor of 1.28 to give the quantity of equivalent hydrated lime, which will be the basis of payment.

- 5.1.4. **Carbide Lime Slurry.** Lime slurry will be measured by the ton (dry weight) as calculated from the minimum percent dry solids content of the slurry, multiplied by the weight of the slurry in tons delivered.

- 5.2. **Lime Treatment.** Lime treatment will be measured by the square yard of surface area. The dimensions for determining the surface area are established by the widths shown on the plans and the lengths measured at placement.

6. PAYMENT

The work performed and materials furnished in accordance with this Item and measured as provided under "Measurement" will be paid in accordance with Section 260.6.1., "Lime," and Section 260.6.2., "Lime Treatment."

Furnishing and delivering new base will be paid for in accordance with Section 247.6.2., "Flexible Base (Roadway Delivery)." Mixing, spreading, blading, shaping, compacting, and finishing new or existing base material will be paid for in accordance with Section 260.6.2., "Lime Treatment." Removal and disposal of existing asphalt concrete pavement will be paid for in accordance with pertinent Items or Article 4.4., "Changes in the Work."

Sprinkling and rolling, except proof rolling, will not be paid for directly but will be subsidiary to this Item, unless otherwise shown on the plans. When proof rolling is shown on the plans or directed by the Engineer, it will be paid for in accordance with Item 216, "Proof Rolling."

Where subgrade is constructed under this Contract, correction of soft spots in the subgrade or existing base will be at the Contractor's expense. Where subgrade is not constructed under this Contract, correction of soft spots in the subgrade or existing base will be paid for in accordance with pertinent Items or Article 4.4., "Changes in the Work."

Where subgrade to be treated under this Contract has sulfates greater than 7,000 ppm, work will be paid for in accordance with Article 4.4., "Changes in the Work."

Asphalt used solely for curing will not be paid for directly but will be subsidiary to this Item. Asphalt placed for curing and priming will be paid for under Item 310, "Prime Coat."

6.1. **Lime.** Lime will be paid for at the unit price bid for "Lime" of one of the following types:

- Hydrated Lime (Dry),
- Hydrated Lime (Slurry),
- Commercial Lime Slurry,
- Quicklime (Dry),
- Quicklime (Slurry), or
- Carbide Lime Slurry.

This price is full compensation for materials, delivery, equipment, labor, tools, and incidentals.

Lime used for reworking a section in accordance with Section 260.4.6., "Reworking a Section," will not be paid for directly but will be subsidiary to this Item.

6.2. **Lime Treatment.** Lime treatment will be paid for at the unit price bid for "Lime Treatment (Existing Material)," "Lime Treatment (New Base)," or "Lime Treatment (Mixing Existing Material and New Base)," for the depth specified. No payment will be made for thickness or width exceeding that shown on the plans. This price is full compensation for shaping existing material, loosening, mixing, pulverizing, spreading, applying lime, compacting, finishing, curing, curing materials, blading, shaping and maintaining shape, replacing mixture, disposing of loosened materials, processing, hauling, preparing secondary subgrade, water, equipment, labor, tools, and incidentals.

Item 276

Cement Treatment (Plant-Mixed)



1. DESCRIPTION

Construct a base course composed of flexible base, hydraulic cement, and water, mixed in an approved plant.

2. MATERIALS

Furnish uncontaminated materials of uniform quality that meet the requirements of the plans and specifications. Notify the Engineer of proposed sources of materials and of changes in material sources. The Engineer will verify that the specification requirements are met before the sources can be used. The Engineer may sample and test project materials at any time before compaction. Use Tex-100-E for material definitions.

- 2.1. **Cement.** Furnish hydraulic cement that meets the requirements of DMS-4600, "Hydraulic Cement," and the Department's *Hydraulic Cement Quality Monitoring Program* (HCQMP). Sources not on the HCQMP will require testing and approval before use.
- 2.2. **Flexible Base.** Furnish base material that meets the requirements of Item 247, "Flexible Base," for the type and grade shown on the plans, before the addition of cement.
- 2.3. **Water.** Furnish water that is free of industrial waste and other objectionable material.
- 2.4. **Asphalt.** Furnish asphalt or emulsion that meets the requirements of Item 300, "Asphalts, Oils, and Emulsions," when permitted for curing purposes as shown on the plans or as directed.
- 2.5. **Mix Design.** Using the materials proposed for the project, the Engineer will determine the target cement content and optimum moisture content necessary to produce a stabilized mixture meeting the strength requirements shown in Table 1 for the class specified on the plans. The mix will be designed in accordance with Tex-120-E. The Contractor may propose a mix design developed in accordance with Tex-120-E. The Engineer will use Tex-120-E to verify the Contractor's proposed mix design before acceptance. The Engineer may use project materials sampled from the plant or the quarry, and sampled by the Engineer or the Contractor, as determined by the Engineer. Limit the amount of asphalt concrete pavement to no more than 50% of the mix unless otherwise shown on the plans or directed.

Table 1
Strength Requirements

Class	7-Day Unconfined Compressive Strength, Min psi
L	500
M	300
N	As shown on the plans

3. EQUIPMENT

Provide machinery, tools, and equipment necessary for proper execution of the work. Provide rollers in accordance with Item 210, "Rolling." Provide proof rollers in accordance with Item 216, "Proof Rolling," when required.

- 3.1. **Cement Storage Facility.** Store cement in closed, weatherproof containers.

- 3.2. **Mixing Plant.** Provide a stationary pugmill, weigh-batch, or continuous mixing plant as approved. Equip plants with automatic proportioning and metering devices that produce a uniform mixture of base material, cement, and water in the specified proportions.
- 3.3. **Spreader Equipment.** Provide equipment that will spread the cement-treated mixture in a uniform layer in 1 pass when shown on the plans. Equip spreaders with electronic grade controls when shown on the plans.

4. CONSTRUCTION

Construct each layer uniformly, free of loose or segregated areas and with the required density and moisture content. Provide a smooth surface that conforms to the typical sections, lines, and grades shown on the plans or established by the Engineer. Start placement operations only when the air temperature is at least 35°F and rising or is at least 40°F. The temperature will be taken in the shade and away from artificial heat. Suspend operations when the Engineer determines that weather conditions are unsuitable.

- 4.1. **Mixing.** Thoroughly mix materials in the proportions designated on the mix design, in a mixing plant that meets the requirements of Section 276.3.2., "Mixing Plant." Mix at optimum moisture content, unless otherwise directed, until a homogeneous mixture is obtained. Do not add water to the mixture after mixing is completed unless directed. The Engineer may sample the mixture to verify strength in accordance with Tex-120-E and adjust cement content to achieve the target strength for work going forward.

- 4.2. **Placing.** Place the cement-treated base on a subgrade or base prepared in accordance with details shown on the plans. Bring the prepared roadway to the moisture content directed. Haul cement-treated base to the roadway in clean trucks and begin placement immediately. Place cement-treated base only on an area where compacting and finishing can be completed during the same working day. Spread and shape in a uniform layer with an approved spreader. Construct individual layers to the thickness shown on the plans. Maintain the shape of the course by blading. Correct or replace segregated areas as directed, at no additional expense to the Department.

Construct vertical joints between new cement-treated base and cement-treated base that has been in place 4 hr. or longer. The vertical face may be created by using a header or by cutting back the face to approximately vertical. Place successive base courses using the same methods as the first course. Offset construction joints by at least 6 in.

- 4.3. **Compaction.** Compact each layer immediately after placing. Complete compaction within 2 hr. after plant-mixing water with dry material. Complete compaction of the final lift within 5 hr. after adding water to the treated base used in the first lift when multiple lifts are permitted.

Moisture content in the mixture at the plant may be adjusted so that during compaction it is within 2.0 percentage points of optimum as determined by Tex-120-E. Measure the moisture content of the material in accordance with Tex-115-E or Tex-103-E during compaction daily and report the results the same, unless otherwise shown on the plans or directed. Maintain uniform moisture content by sprinkling the treated material in accordance with Item 204, "Sprinkling."

Begin rolling longitudinally at the sides and proceed towards the center, overlapping on successive trips by at least 1/2 the width of the roller unit. Begin rolling at the low side and progress toward the high side on superelevated curves. Offset alternate trips of the roller. Operate rollers at a speed between 2 and 6 mph, as directed.

Achieve at least 95% of maximum density determined in accordance with Tex-120-E when compaction is complete. The Engineer will determine roadway density and moisture content in accordance with Tex-115-E. Remove material that does not meet density requirements. Remove areas that lose required stability, compaction, or finish. Replace with cement-treated mixture, compact, and test in accordance with density control methods.

The Engineer may accept the section if no more than 1 of the 5 most recent density tests is below the specified density and the failing test is no more than 3 pcf below the specified density.

- 4.4. **Finishing.** Clip, skin, or tight blade the surface of the cement-treated material with a maintainer or subgrade trimmer to a depth of approximately 1/4 in. immediately after completing compaction. Remove loosened material and dispose of at an approved location. Roll the clipped surface immediately with a pneumatic tire roller until a smooth surface is attained. Add small increments of water as needed during rolling. Shape and maintain the course and surface in conformity with the typical sections, lines, and grades shown on the plans or as directed.

Trim grade deviations greater than 1/4 in. in 16 ft. measured longitudinally or greater than 1/4 in. over the entire width of the cross-section in areas where surfacing is to be placed. Remove excess material, reshape, and then roll with a pneumatic tire roller. Correct as directed if material is more than 1/4 in. low. Do not surface patch.

- 4.5. **Microcracking.** Maintain moisture content of the finished cement-treated base for a period of 24 to 48 hr. when shown on the plans. Roll the finished course with a vibratory roller to induce microcracking during this time, but not sooner than 24 hrs. The vibratory roller must be in accordance with Item 210, "Rolling," with a static weight equal to or more than 12 tons and the vibratory drum must be not less than 20 in. wide. The roller must travel at a speed of 2 mph, vibrating at maximum amplitude, and make 2 to 4 passes with 100% coverage exclusive of the outside 1 ft. of the surface crown, unless otherwise directed by the Engineer. Additional passes may be required to achieve the desired crack pattern as directed. Notify the Engineer 24 hr. before the microcracking begins.
- 4.6. **Curing.** Cure for at least 3 days by sprinkling in accordance with Item 204, "Sprinkling," or by applying an asphalt material at the rate of 0.05 to 0.20 gal. per square yard, as shown on the plans or directed. When a section is microcracked, cure section for an additional 2 days after microcracking. Maintain the moisture content during curing at no lower than 2 percentage points below optimum. Continue curing until placing another course.

5. MEASUREMENT

Cement-treated base will be measured by the ton, cubic yard, or square yard as a composite mixture of cement, flexible base, and recycled materials.

Measurement by the cubic yard in final position and square yard is a plans quantity measurement. The quantity to be paid for is the quantity shown in the proposal unless modified by Article 9.2., "Plans Quantity Measurement." Additional measurements or calculations will be made if adjustments of quantities are required.

Measurement is further defined for payment as follows:

- 5.1. **Cubic Yard in Vehicles.** Cement-treated base will be measured by the cubic yard in vehicles as delivered on the road.
- 5.2. **Cubic Yard in Final Position.** Cement-treated base will be measured by the cubic yard in its completed and accepted final position. The volume of each course will be computed in-place between the original subgrade surfaces and the lines, grades, and slopes of the accepted base course as shown on the plans, and calculated by the method of average end areas.
- 5.3. **Square Yard.** Cement-treated base will be measured by the square yard of surface area. The dimensions for determining the surface area are established by the dimensions shown on the plans.
- 5.4. **Ton.** Cement-treated base will be measured by the ton (dry weight) in vehicles as delivered on the road. The dry weight is determined by deducting the weight of the moisture in the material at the time of weighing from

the gross weight of the material. The Engineer will determine the moisture content in the material in accordance with Tex-103-E from samples taken at the time of weighing.

When material is measured in trucks, the weight of the material will be determined on certified scales, or the Contractor must provide a set of standard platform truck scales at an approved location. Scales must conform to the requirements of Item 520, "Weighing and Measuring Equipment."

6. PAYMENT

The work performed and materials furnished in accordance with this Item and measured as provided under "Measurement" will be paid for at the unit price bid for "Cement Treatment (Plant-Mix)" of the class (strength), flexible base type, grade, and thickness (for square yard measurement) specified. For cubic yard measurement, "In Vehicle" or "In Final Position" will be specified. This price is full compensation for furnishing and disposing of materials (including cement and base); storing, mixing, hauling, placing, sprinkling, compacting, microcracking, finishing, curing, and maintaining and reworking treated base; and equipment, labor, tools, and incidentals.

Sprinkling and rolling, except proof rolling, will not be paid for directly but will be subsidiary to this Item, unless otherwise shown on the plans. When proof rolling is shown on the plans or directed by the Engineer, it will be paid for in accordance with Item 216, "Proof Rolling."

Where subgrade or base courses are constructed under this Contract, correction of soft spots will be at the Contractor's expense. Where subgrade or base is not constructed under this Contract, correction of soft spots will be paid for in accordance with pertinent Items and Article 4.4., "Changes in the Work."

Asphalt used solely for curing will not be paid for directly but will be subsidiary to this Item. Asphalt placed for curing and priming will be paid for under Item 310, "Prime Coat."

Removal and disposal of existing asphalt concrete pavement will be paid for in accordance with pertinent Items or Article 4.4., "Changes in the Work."

- 6.1. **Thickness Measurement for Cubic Yard In Final Position and Square Yard Payment Adjustment.**
Before final acceptance, the Engineer will select the locations of tests within each unit and measure the treated base depths in accordance with Tex-140-E.
- 6.1.1. **Units for Payment Adjustment.**
 - 6.1.1.1. **Roadways and Shoulders.** Units for applying a payment adjustment for thickness to roadways and shoulders are defined as 1,000 ft. of treated base in each placement width. The last unit in each placement width will be 1,000 ft. plus the fractional part of 1,000 ft. remaining. Placement width is the width between longitudinal construction joints. For widening, the placement width is the average width placed of the widened section that is deficient in thickness.
 - 6.1.1.2. **Ramps and Other Areas.** Units are defined as 2,000 sq. yd. or fraction thereof for establishing an adjusted unit price for ramps, intersections, irregular sections, crossovers, entrances, partially completed units, transitions to ramps, and other areas designated by the Engineer.
- 6.1.2. **Price Adjustments of Deficient Areas.**
 - 6.1.2.1. **Thickness Deficiency \leq 1.0 in.** Table 2 will govern the price adjustment for each unit with deficient areas \leq 1.0 in.

Table 2
Measurements and Price Adjustment for Each Unit

Thickness Deficiency	Additional Measurements	Average Thickness Deficiency of 3 Measurements		Price Adjustment
≤ 0.5 in.	None	N/A		Full Payment
> 0.5 in.	2	≤ 0.5 in.		Full Payment
		> 0.5 in.	≤ 0.8 in.	75% Payment
		> 0.8 in.	≤ 1.0 in.	50% Payment
		> 1.0 in.		In accordance with Section 276.6.1.2.2., "Thickness Deficiency ≥ 1.0 in."

- 6.1.2.2. **Thickness Deficiency ≥ 1.0 in.** Remove and replace areas of treated base found deficient in thickness by more than 1.0 in., unless otherwise approved. Take exploratory measurements at 50-ft. intervals parallel to the centerline in each direction from the deficient measurement until a measurement is not deficient by more than 1.0 in. The minimum limit of non-pay will be 100 ft.
- 6.2. **Excess Thickness and Width.** For cubic yard in final position and square yard measurement, no additional payment will be made for thickness or width exceeding that shown on the plans.